

SIZE SPECIFICATIONS:

88"W x 88"H







FRONT VIEW



SIDE VIEW



ISOMETRIC VIEW

PARTS	CODE	QTY
	TC1	2
	S2	8
	S3	4
	BC1	2
	B1	2

FRAME ASSEMBLY

STEP 1: LOWER SECTION

PARTS REQUIRED: 2-BC1, 2-D5B1, 2-S2, 1-S3

- ▶ Attach the base D5B1 to part BC1 by pushing and turning until fully inserted.
- ▶ Follow the number sequence
- ▶ Connect S2 to BC1
- ▶ Connect S3 to S2
- ▶ Connect S2 to S3
- ▶ Connect BC1 with Base to S2

STEP 2:

PARTS REQUIRED: 2-S2, 2-S3

- ▶ Take Lower Section from STEP 1
- ▶ Follow the number sequence
- ▶ Connect S2 to BC1
- ▶ Connect S3 to S2
- ▶ Repeat to complete other side

STEP 3:

PARTS REQUIRED: 2-TC1, 4-S2, 1-S3

- ▶ Follow the number sequence
- ▶ Connect S2 to TC1
- ▶ Connect TC1 to S2
- ▶ Connect S3 to S2
- ▶ Connect S2 to S3
- ▶ Connect TC1 to S2
- ▶ Connect S2 to TC1
- ▶ Attach the completed upper section to the lower section to complete the frame

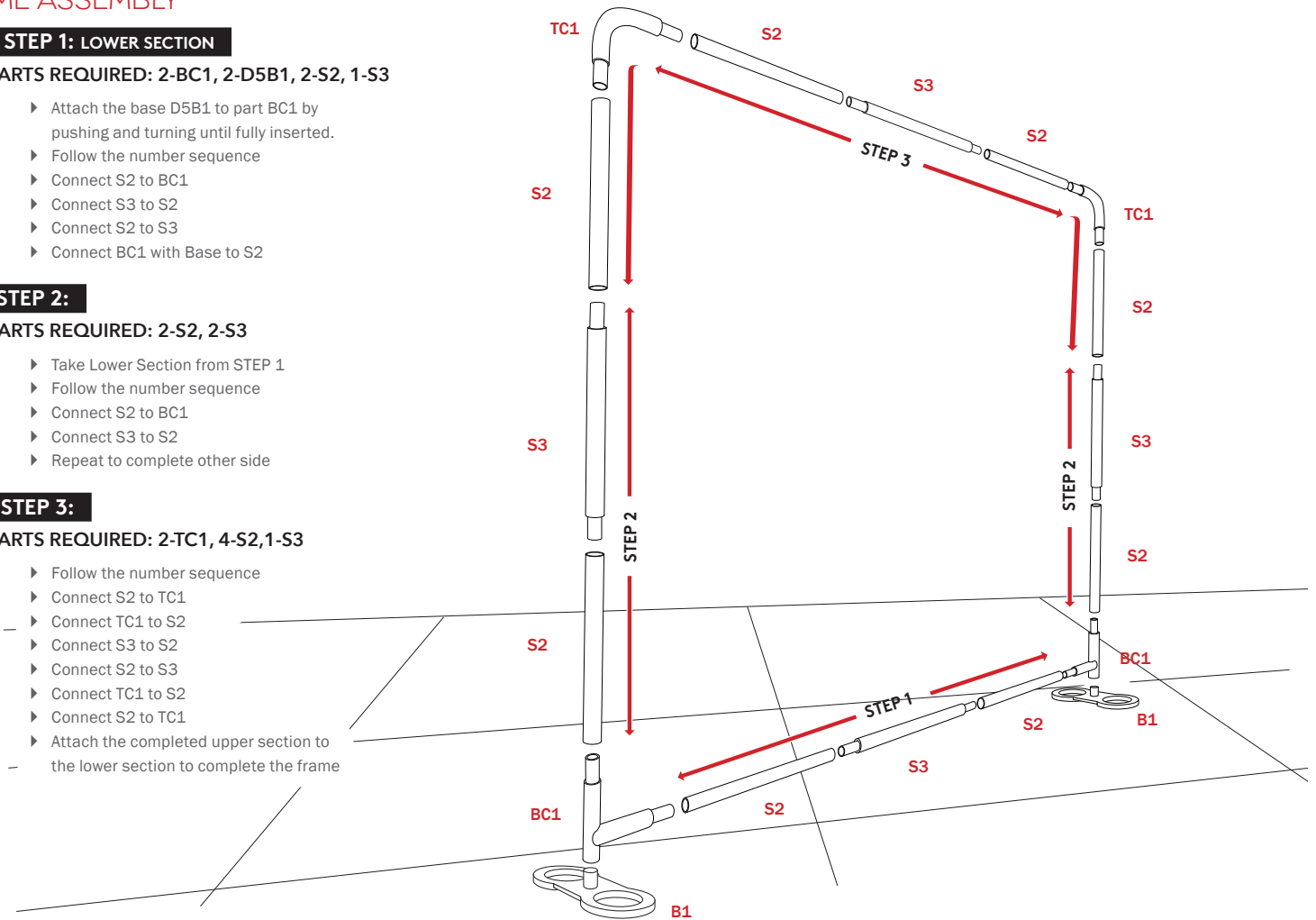

FABRIC INSTALLATION

- ▶ Make sure that floor is clean. If possible use a drop cloth. Lay frame on the floor
- ▶ Locate the opening on the fabric
- ▶ Make sure that zipper is open
- ▶ Drape fabric like a pillow cover to the frame starting at the top
- ▶ Pull the fabric part way down and stand frame up
- ▶ Pull fabric completely down and close zipper

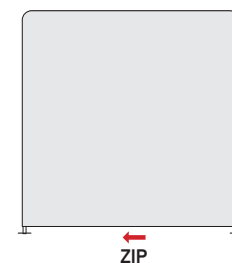
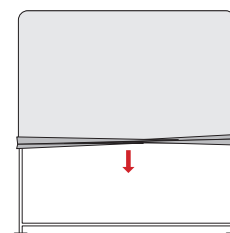
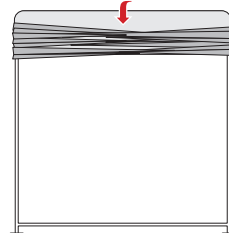

This document contains proprietary information. No portion may be disclosed to other, reproduced or used in any way without our written authorization.

©2018 McRae Imaging Inc.

SIZE SPECIFICATIONS:

115"W x 88"H



FRONT VIEW



SIDE VIEW



ISOMETRIC VIEW

PARTS	CODE	QTY
	TC1	2
	S2	8
	S3	4
	S4	2
	BC1	2
	B1	2

FRAME ASSEMBLY

STEP 1: LOWER SECTION

PARTS REQUIRED: 2-BC1, 2-B1, 2-S2, 1-S3, 1-S4

- ▶ Attach the base B1 to part BC1 by using the locking pin
- ▶ Follow the number sequence
- ▶ Connect S4 to BC1
- ▶ Connect S2 to S4
- ▶ Connect S3 to S2
- ▶ Connect S2 to S3
- ▶ Connect BC1 with Base to S2.

STEP 2:

PARTS REQUIRED: 2-S2, 2-S3

- ▶ Take Lower Section from STEP 1
- ▶ Follow the number sequence
- ▶ Connect S2 to BC1
- ▶ Connect S3 to S2
- ▶ Repeat to complete other side

STEP 3:

PARTS REQUIRED: 2-TC1, 4-S2, 1-S3

- ▶ Follow the number sequence
- ▶ Connect S2 to TC1
- ▶ Connect TC1 to S4
- ▶ Connect S2 to S4
- ▶ Connect S3 to S2
- ▶ Connect S2 to S3
- ▶ Connect TC1 to S2
- ▶ Connect S2 to TC1
- ▶ Attach the completed upper section to the lower section to complete the frame

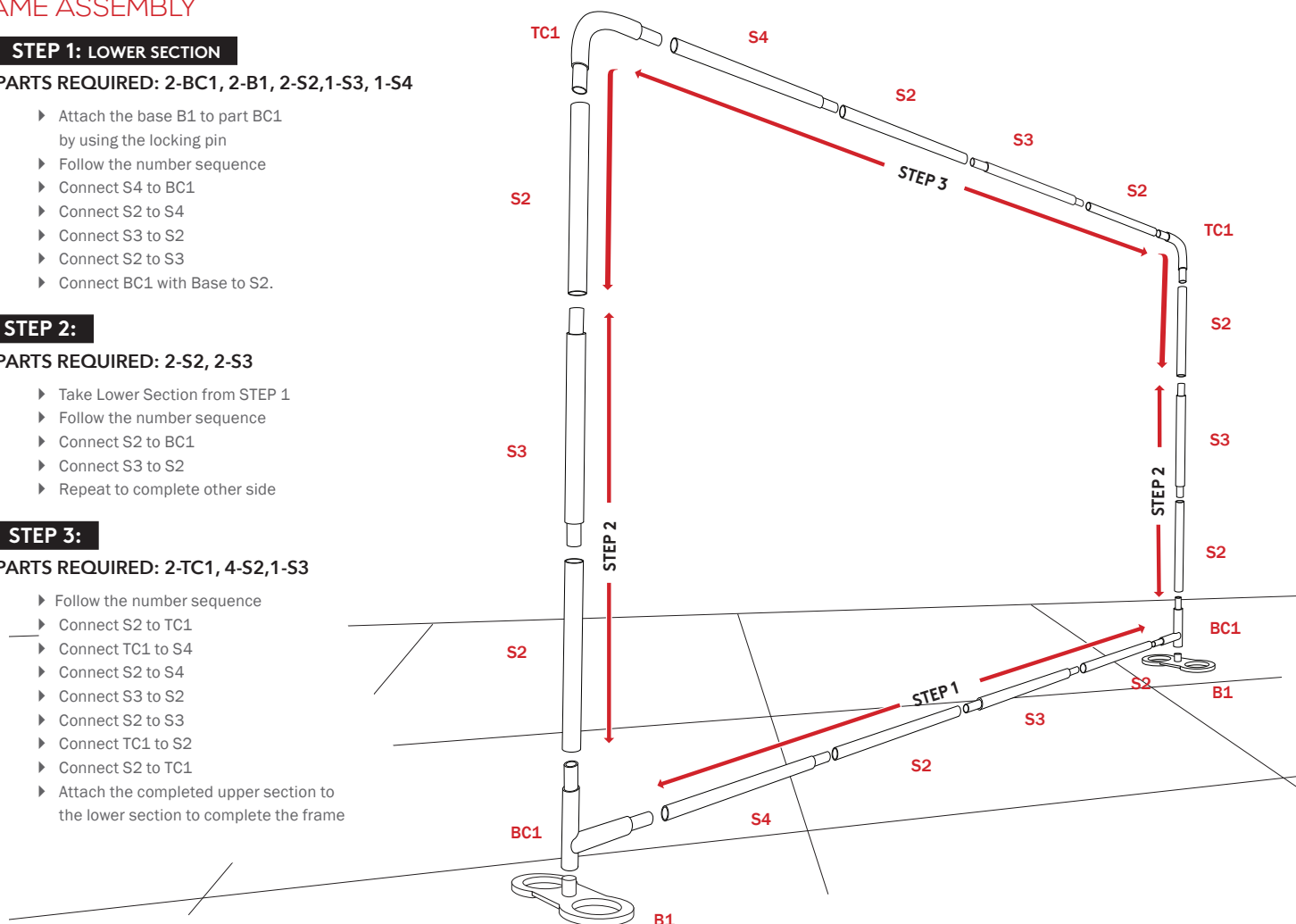

FABRIC INSTALLATION

- ▶ Make sure that floor is clean. If possible use a drop cloth. Lay frame on the floor
- ▶ Locate the opening on the fabric
- ▶ Make sure that zipper is open
- ▶ Drape fabric like a pillow cover to the frame starting at the top
- ▶ Pull the fabric part way down and stand frame up
- ▶ Pull fabric completely down and close zipper

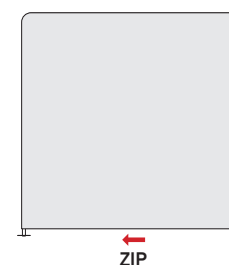
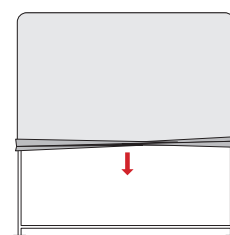
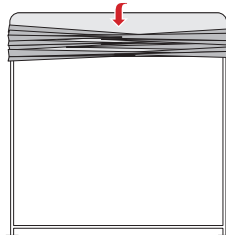

This document contains proprietary information. No portion may be disclosed to other, reproduced or used in any way without our written authorization.

©2018 McRae Imaging Inc.

SIZE SPECIFICATIONS:

228.75"W x 88"H



FRONT VIEW



SIDE VIEW

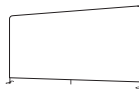

ISOMETRIC VIEW

PARTS	CODE	QTY
	TC1	2
	TC3	1
	S2	14
	S3	7
	S4	4
	BC4	1
	BC1	2
	B1	2

This document contains proprietary information. No portion may be disclosed to other, reproduced or used in any way without our written authorization.

©2018 McRae Imaging Inc.

FRAME ASSEMBLY

STEP 1: LOWER SECTION

PARTS REQUIRED: 2-BC1, 2-B1, 4-S2, 2-S3, 2-S4, 1-BC4

- ▶ Attach the base B1 to part BC1 by using the locking pin
- ▶ Follow the number sequence
- ▶ Connect S4 to BC1
- ▶ Connect S2 to S4
- ▶ Connect S3 to S2
- ▶ Connect S2 to S3
- ▶ Connect BC4 S2
- ▶ Connect S4 to BC4
- ▶ Connect S2 to S4
- ▶ Connect S3 to S2
- ▶ Connect S2 to S3
- ▶ Connect BC1 with Base to S2

STEP 2:

PARTS REQUIRED: 3-S2, 3-S3

- ▶ Take Lower Section from STEP 1
- ▶ Follow the number sequence
- ▶ Connect S2 to BC1
- ▶ Connect S3 to S2
- ▶ Repeat to complete other side
- ▶ Connect S2 to BC4
- ▶ Connect S3 to S2

STEP 3:

PARTS REQUIRED: 2-TC1, 4-S2, 2-S3, 2-S4, 1-TC3

- ▶ Follow the number sequence
- ▶ Connect S2 to TC1
- ▶ Connect TC1 to S4
- ▶ Connect S2 to S4
- ▶ Connect S3 to S2
- ▶ Connect S2 to S3
- ▶ Connect TC3 to S2
- ▶ Connect S2 to TC3
- ▶ Connect S2 to TC3
- ▶ Connect TC3 to S4
- ▶ Connect S2 to S4
- ▶ Connect S3 to S2
- ▶ Connect S2 to S3
- ▶ Connect TC1 to S2
- ▶ Attach the completed upper section to the lower section to complete the frame

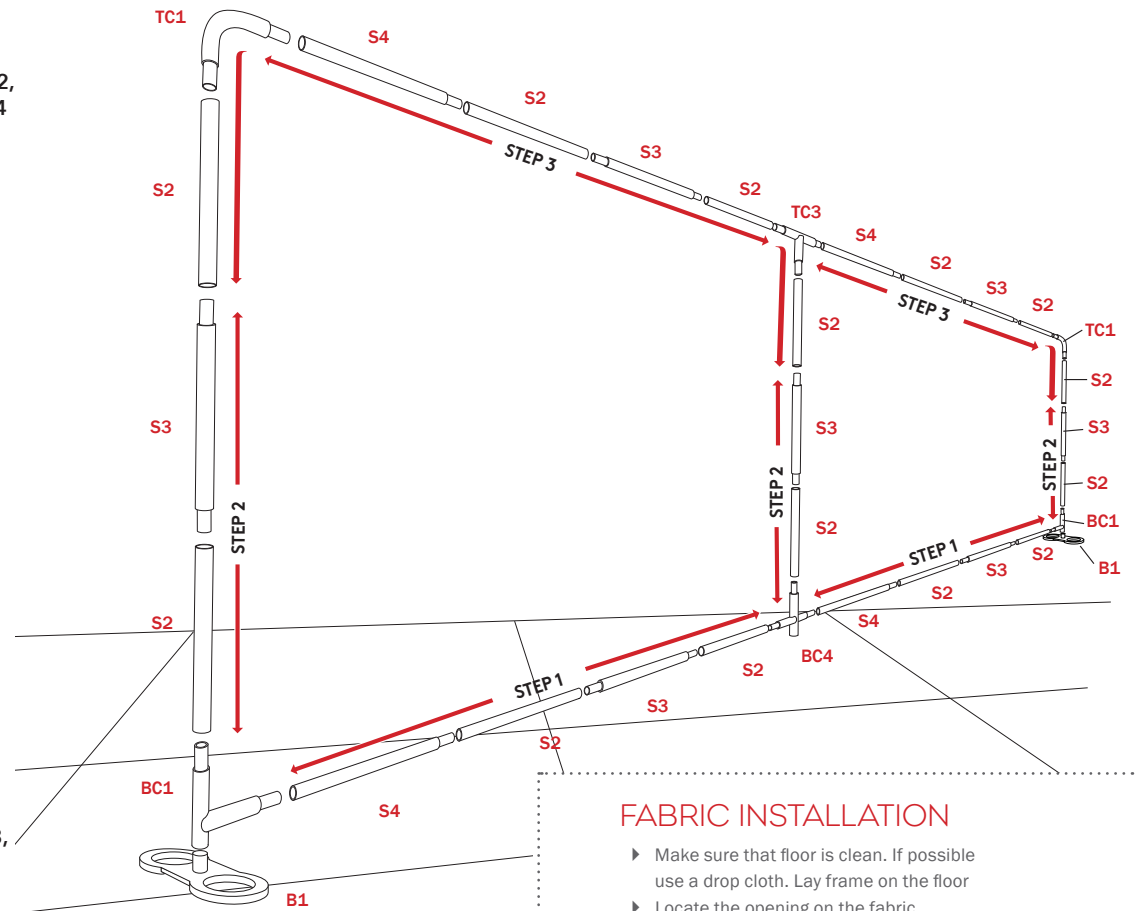

FABRIC INSTALLATION

- ▶ Make sure that floor is clean. If possible use a drop cloth. Lay frame on the floor
- ▶ Locate the opening on the fabric
- ▶ Make sure that zipper is open
- ▶ Drape fabric like a pillow cover to the frame starting at the top
- ▶ Pull the fabric part way down and stand frame up
- ▶ Pull fabric completely down and close zipper

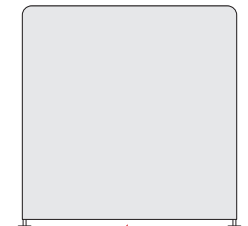
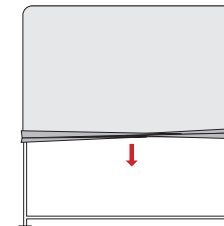
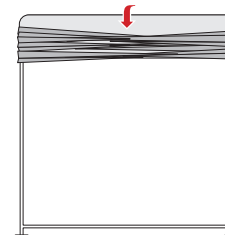

ZIP

SIZE SPECIFICATIONS:

94"W x 88"H



FRONT VIEW



SIDE VIEW



ISOMETRIC VIEW

PARTS	CODE	QTY
	TC1	2
	TC2	1
	S2	6
	S3	3
	C1	4
	C4	4
	BC1	2
	BC2	1
	B1	2

FRAME ASSEMBLY

STEP 1: LOWER SECTION

PARTS REQUIRED: 2-BC1, 1- BC2, 2-B1, 2-C1, 2-C4

- ▶ Attach the base B1 to part BC1 by using the locking pin
- ▶ Follow the number sequence
- ▶ Connect C1 to BC1
- ▶ Connect C4 to C1
- ▶ Connect BC2 to C4
- ▶ Connect C4 to BC2
- ▶ Connect C1 to C4
- ▶ Connect BC1 to C1

STEP 2:

PARTS REQUIRED: 3-S2, 3-S3

- ▶ Take Lower Section from STEP 1
- ▶ Follow the number sequence
- ▶ Connect S2 to BC1
- ▶ Connect S3 to S2
- ▶ Repeat to complete other side
- ▶ Connect S2 to BC2
- ▶ Connect S3 to S2

STEP 3:

PARTS REQUIRED: 2-TC1, 1-TC2, 2-C1, 2-C4, 3-S2

- ▶ Follow the number sequence
- ▶ Connect S2 to TC1
- ▶ Connect TC1 to C1
- ▶ Connect C4 to C1
- ▶ Connect TC2 to C4
- ▶ Connect C4 to TC4
- ▶ Connect C1 to C4
- ▶ Connect TC1 to C1
- ▶ Connect S2 to TC1
- ▶ Attach the completed upper section to the lower section to complete the frame

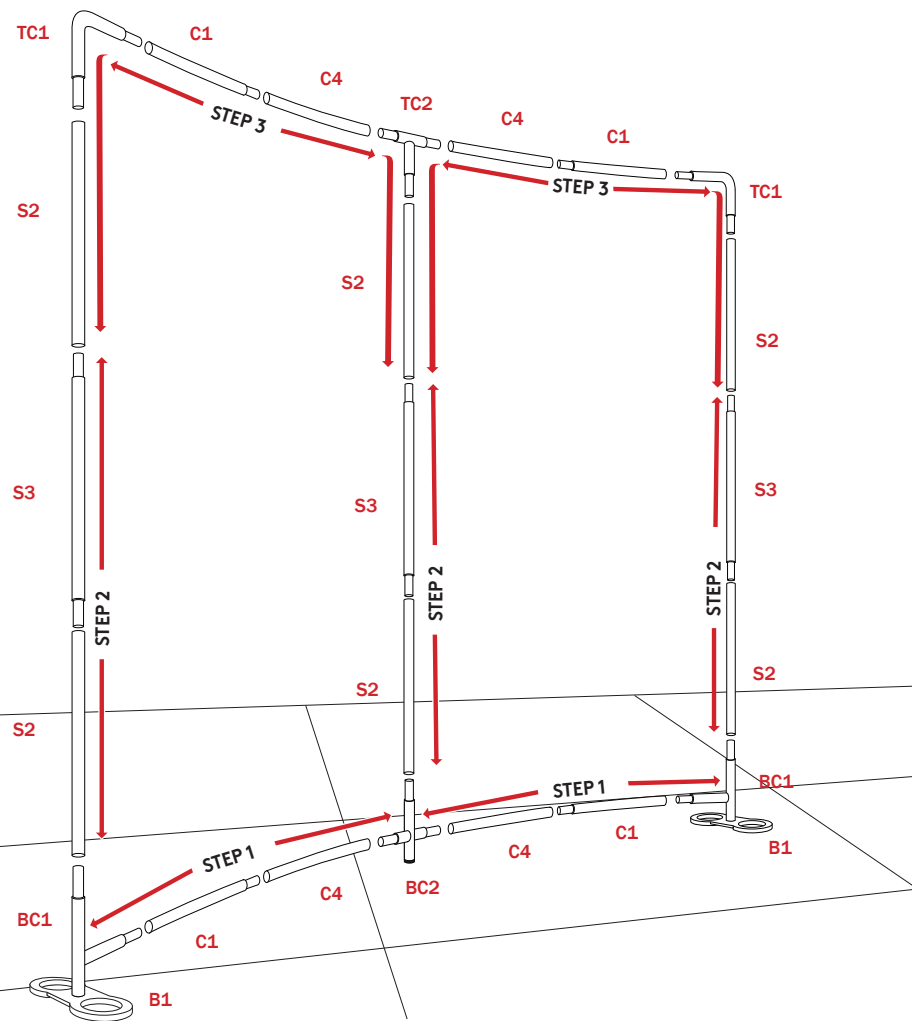

FABRIC INSTALLATION

- ▶ Make sure that floor is clean. If possible use a drop cloth. Lay frame on the floor
- ▶ Locate the opening on the fabric
- ▶ Make sure that zipper is open
- ▶ Drape fabric like a pillow cover to the frame starting at the top
- ▶ Pull the fabric part way down and stand frame up
- ▶ Pull fabric completely down and close zipper

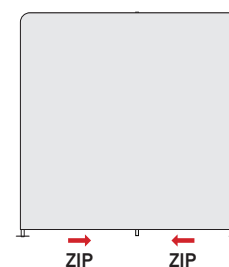
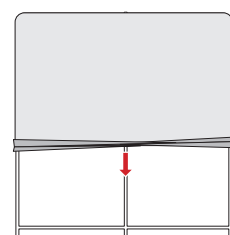
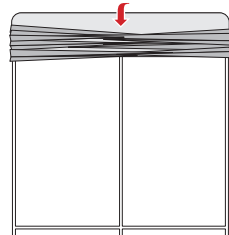

This document contains proprietary information. No portion may be disclosed to other, reproduced or used in any way without our written authorization.

©2018 McRae Imaging Inc.

SIZE SPECIFICATIONS:

108"W x 88"H



PARTS	CODE	QTY
	TC1	2
	TC2	1
	S2	6
	S3	3
	C1	4
	C4	4
	BC1	2
	BC2	1
	B1	2

FRAME ASSEMBLY

STEP 1: LOWER SECTION

PARTS REQUIRED: 2-BC1, 1- BC2, 2-B1, 2-C2, 2-C1

- ▶ Attach the base B1 to part BC1 by using the locking pin
- ▶ Follow the number sequence
- ▶ Connect C1 to BC1
- ▶ Connect C2 to C1
- ▶ Connect BC2 to C2
- ▶ Connect C2 to BC2
- ▶ Connect C1 to C2
- ▶ Connect BC1 to C1
- ▶ Connect BC1 with Base to S2

STEP 2:

PARTS REQUIRED: 3-S2, 3-S3

- ▶ Take Lower Section from STEP 1
- ▶ Follow the number sequence
- ▶ Connect S2 to BC1
- ▶ Connect S3 to S2
- ▶ Repeat to complete other side
- ▶ Connect S2 to BC2
- ▶ Connect S3 to S2

STEP 3:

PARTS REQUIRED: 2-TC1, 1-TC2, 2-C2, 2-C1, 3-S2

- ▶ Follow the number sequence
- ▶ Connect S2 to TC1
- ▶ Connect TC1 to C1
- ▶ Connect C2 to C1
- ▶ Connect TC2 to C2
- ▶ Connect C2 to TC2
- ▶ Connect C1 to C2
- ▶ Connect TC1 to C2
- ▶ Connect S2 to TC1
- ▶ Attach the completed upper section to the lower section to complete the frame

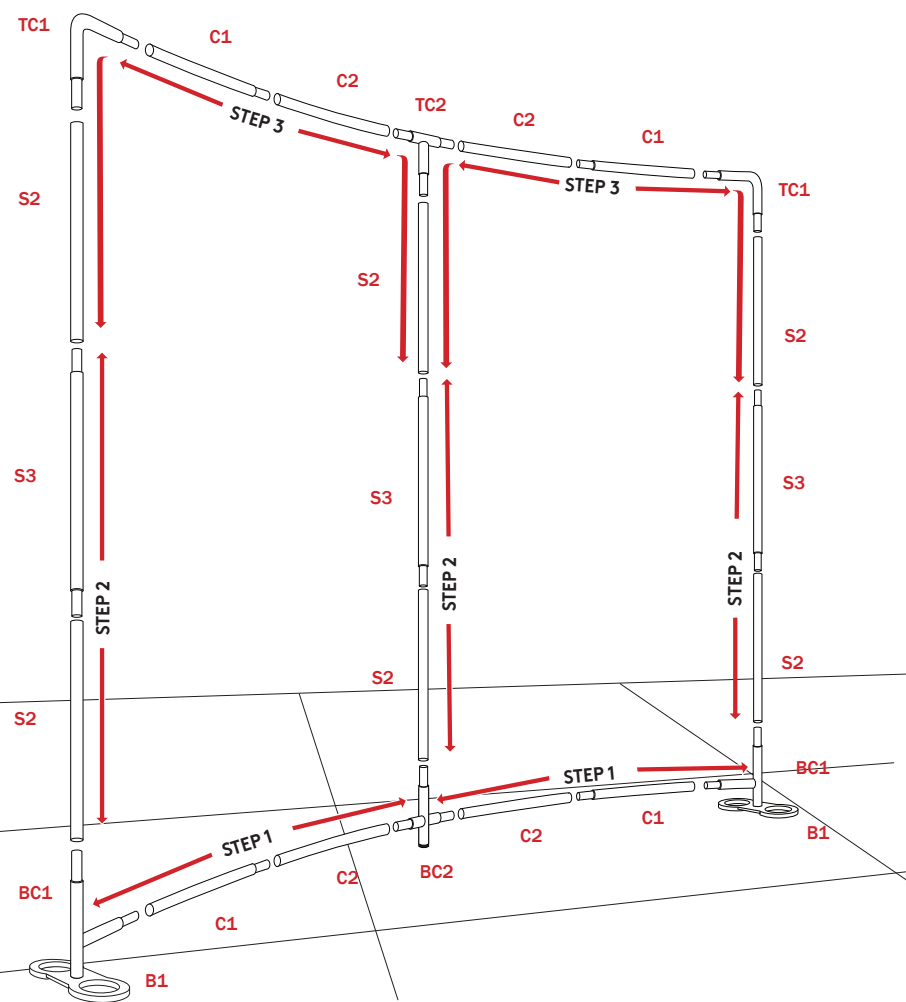

FABRIC INSTALLATION

- ▶ Make sure that floor is clean. If possible use a drop cloth. Lay frame on the floor
- ▶ Locate the opening on the fabric
- ▶ Make sure that zipper is open
- ▶ Drape fabric like a pillow cover to the frame starting at the top
- ▶ Pull the fabric part way down and stand frame up
- ▶ Pull fabric completely down and close zipper

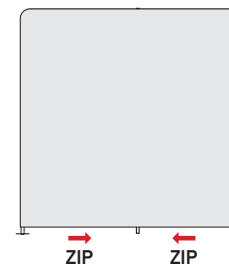
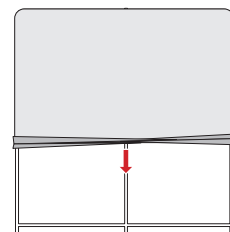
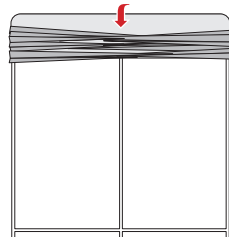

This document contains proprietary information. No portion may be disclosed to other, reproduced or used in any way without our written authorization.

©2018 McRae Imaging Inc.

SIZE SPECIFICATIONS:

114"W x 88"H



PARTS	CODE	QTY
	TC1	2
	TC2	1
	S2	6
	S3	3
	C5	4
	C2	4
	BC1	2
	BC2	1
	B1	2

FRAME ASSEMBLY

STEP 1: LOWER SECTION

PARTS REQUIRED: 2-BC1, 1-BC2, 2-B1, 2-C2, 2-C5

- ▶ Attach the base B1 to part BC1 by using the locking pin
- ▶ Follow the number sequence
- ▶ Connect C5 to BC1
- ▶ Connect C2 to C5
- ▶ Connect BC2 to C2
- ▶ Connect C2 to BC2
- ▶ Connect C5 to C2
- ▶ Connect BC1 to C5
- ▶ Connect BC1 with Base to S2

STEP 2:

PARTS REQUIRED: 3-S2, 3-S3

- ▶ Take Lower Section from STEP 1
- ▶ Follow the number sequence
- ▶ Connect S2 to BC1
- ▶ Connect S3 to S2
- ▶ Repeat to complete other side
- ▶ Connect S2 to BC2
- ▶ Connect S3 to S2

STEP 3:

PARTS REQUIRED: 2-TC1, 1-TC2, 2-C2, 2-C5, 3-S2

- ▶ Follow the number sequence
- ▶ Connect S2 to TC1
- ▶ Connect TC1 to C5
- ▶ Connect C2 to C5
- ▶ Connect TC2 to C2
- ▶ Connect C2 to TC2
- ▶ Connect C5 to C2
- ▶ Connect TC1 to C2
- ▶ Connect S2 to TC1
- ▶ Attach the completed upper section to the lower section to complete the frame

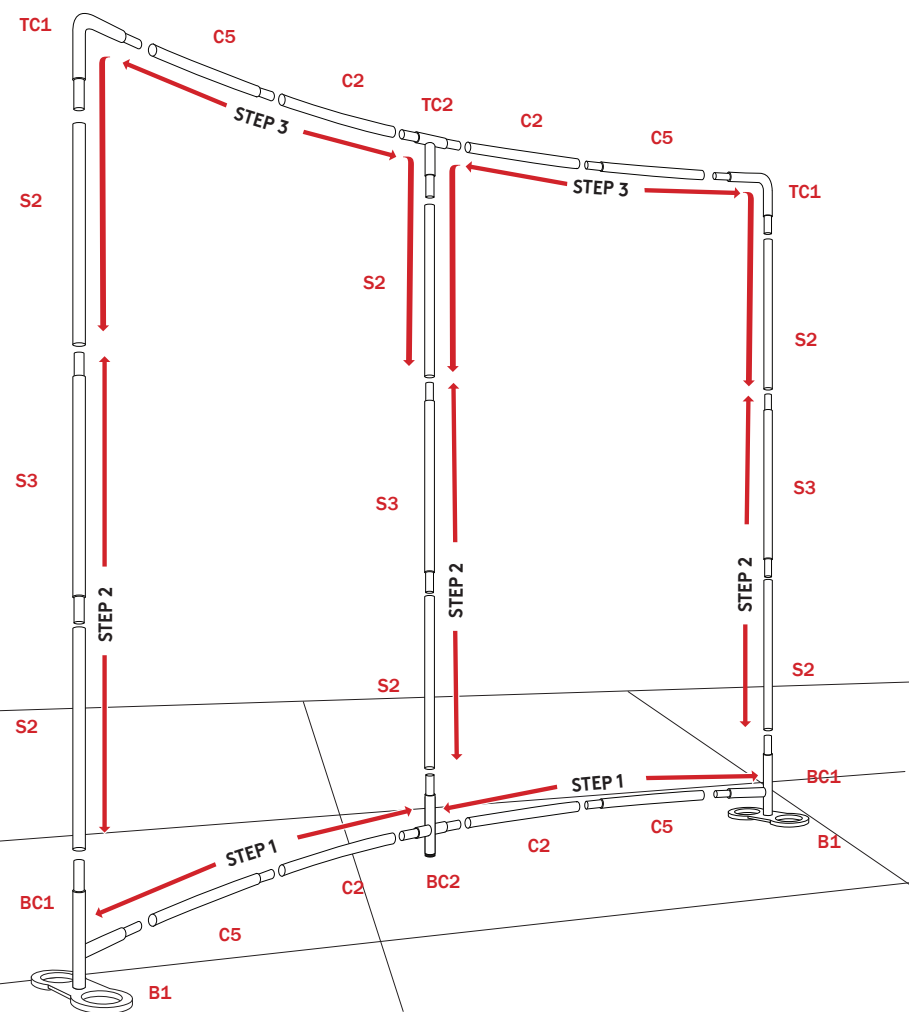

FABRIC INSTALLATION

- ▶ Make sure that floor is clean. If possible use a drop cloth. Lay frame on the floor
- ▶ Locate the opening on the fabric
- ▶ Make sure that zipper is open
- ▶ Drape fabric like a pillow cover to the frame starting at the top
- ▶ Pull the fabric part way down and stand frame up
- ▶ Pull fabric completely down and close zipper

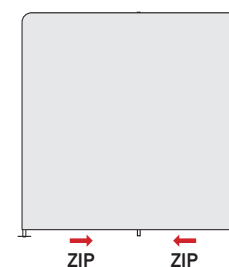
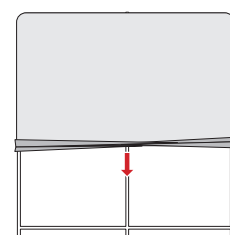
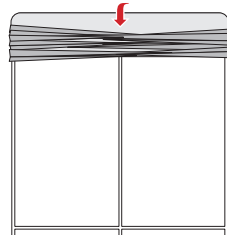

This document contains proprietary information. No portion may be disclosed to other, reproduced or used in any way without our written authorization.

©2018 McRae Imaging Inc.

SIZE SPECIFICATIONS:
114"W x 88"H



FRONT VIEW

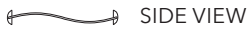

SIDE VIEW



ISOMETRIC VIEW

PARTS	CODE	QTY
	TC1	2
	TC2	1
	S2	6
	S3	3
	C5	4
	C2	4
	BC2	1
	BC1	2
	B1	2

FRAME ASSEMBLY

STEP 1: LOWER SECTION

PARTS REQUIRED:
2-BC1, 2-D5B1, 2-C1, 2-C3, 1-BC2

- ▶ Attach the base B1 to part BC1 by pushing and turning until fully inserted
- ▶ Follow the number sequence
- ▶ Connect C1 to BC1
- ▶ Connect C3 to C1
- ▶ Connect BC3 to C3
- ▶ Connect C3 to BC2
- ▶ Connect C1 to C3
- ▶ Connect BC1 with Base to C1

STEP 2:

PARTS REQUIRED: 3-S2, 3-S3

- ▶ Take Lower Section from STEP 1
- ▶ Follow the number sequence
- ▶ Connect S2 to BC1
- ▶ Connect S3 to S2
- ▶ Repeat to complete other side
- ▶ Connect S2 to BC2
- ▶ Connect S3 to S2

STEP 3:

PARTS REQUIRED:
2-TC1, 2-C1, 2-C3, 3-S2, 1-TC2

- ▶ Follow the number sequence
- ▶ Connect S2 to TC1
- ▶ Connect C1 to TC1
- ▶ Connect C3 to C1
- ▶ Connect TC2 to C3
- ▶ Connect C3 to TC2
- ▶ Connect C1 to C3
- ▶ Connect TC1 to C1
- ▶ Connect S2 to TC1
- ▶ Attach the completed upper section to the lower section to complete the frame

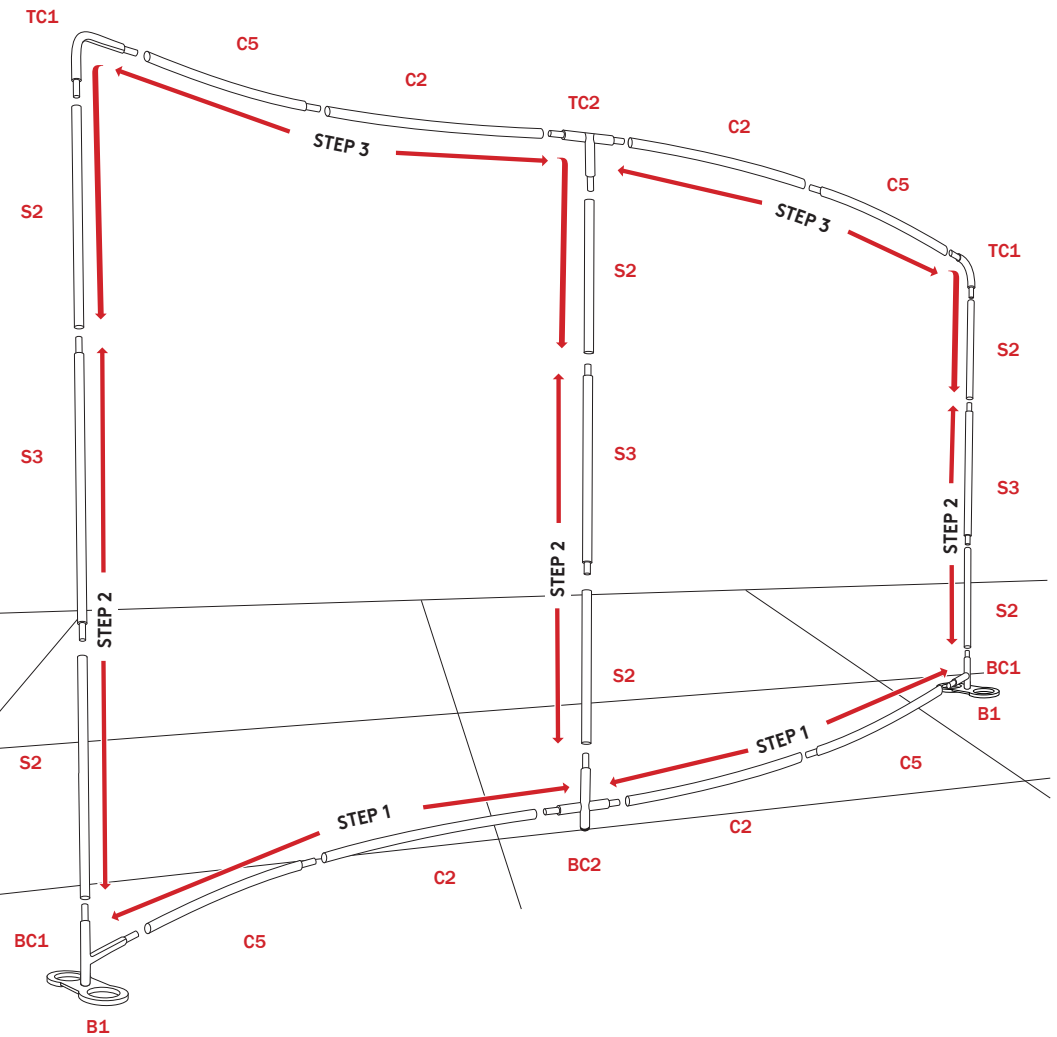

FABRIC INSTALLATION

- ▶ Make sure that floor is clean. If possible use a drop cloth. Lay frame on the floor
- ▶ Locate the opening on the fabric
- ▶ Make sure that zipper is open
- ▶ Drape fabric like a pillow cover to the frame starting at the top
- ▶ Pull the fabric part way down and stand frame up
- ▶ Pull fabric completely down and close zipper

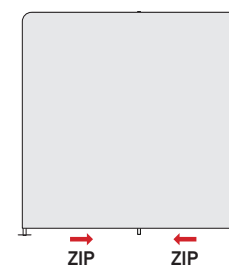
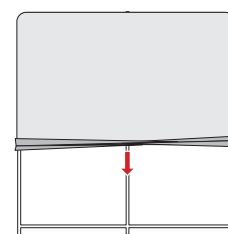
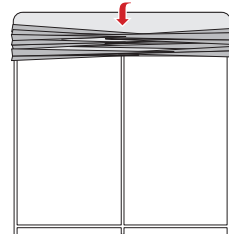

This document contains proprietary information. No portion may be disclosed to other, reproduced or used in any way without our written authorization.

©2018 McRae Imaging Inc.

SIZE SPECIFICATIONS:

88"W x 97.5"H



FRONT VIEW



SIDE VIEW

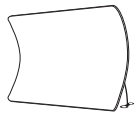

ISOMETRIC VIEW

PARTS	CODE	QTY
	TC1	4
	S2	4
	S3	2
	C1	4
	C2	2
	BC4	2
	B1	2

FRAME ASSEMBLY

STEP 1: LOWER SECTION

PARTS REQUIRED: 2-TC1, 2-BC4, 2-B1, 2-S2, 1-S3

- ▶ Attach the base B1 to part BC4 by using the locking pin
- ▶ Follow the number sequence
- ▶ Connect corner TC1 to BC4
- ▶ Connect S2 to TC1
- ▶ Connect S3 to S2
- ▶ Connect S2 to S3
- ▶ Connect TC1 to S2
- ▶ Connect BC4 with Base to TC1

STEP 2:

PARTS REQUIRED: 2-C1, 2-C23

- ▶ Take Lower Section from STEP 1
- ▶ Follow the number sequence
- ▶ Connect C1 to BC4
- ▶ Connect C2 to C1
- ▶ Repeat to complete other side

STEP 3:

PARTS REQUIRED: 2-TC1, 1-TC2, 2-C2, 2-C1, 3-S2

- ▶ Follow the number sequence
- ▶ Connect C1 to C2
- ▶ Connect TC1 to C2
- ▶ Connect S2 to TC1
- ▶ Connect S3 to S2
- ▶ Connect TC1 to S2
- ▶ Connect C1 to TC1
- ▶ Connect C1 to C2
- ▶ Attach the completed upper section to the lower section to complete the frame

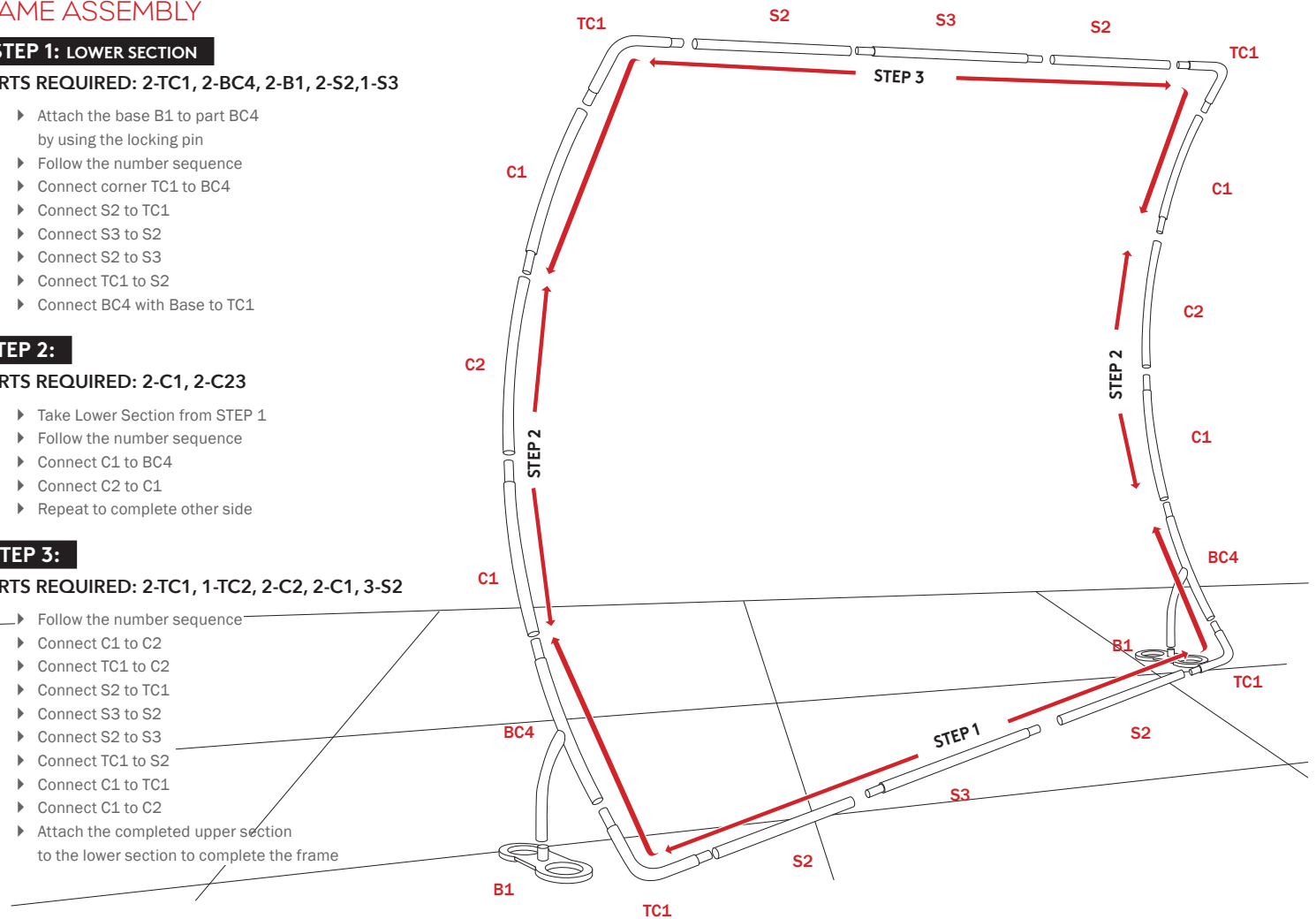

FABRIC INSTALLATION

- ▶ Make sure that floor is clean. If possible use a drop cloth. Lay frame on the floor
- ▶ Locate the opening on the fabric
- ▶ Make sure that zipper is open
- ▶ Drape fabric like a pillow cover to the frame starting at the top
- ▶ Pull the fabric part way down and stand frame up
- ▶ Pull fabric completely down and close zipper

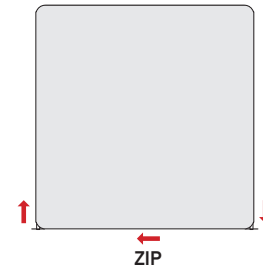
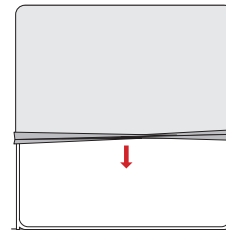
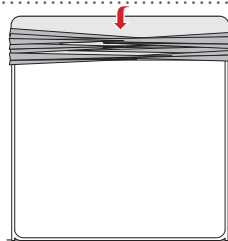

This document contains proprietary information. No portion may be disclosed to other, reproduced or used in any way without our written authorization.

©2018 McRae Imaging Inc.

SIZE SPECIFICATIONS:

115"W x 97.5"H



FRONT VIEW



SIDE VIEW



ISOMETRIC VIEW

PARTS	CODE	QTY
	TC1	4
	S2	4
	S3	2
	S4	2
	C1	4
	C2	2
	BC4	2
	B1	2

FRAME ASSEMBLY

STEP 1: BOTTOM SECTION

PARTS REQUIRED: 2-TC1, 2-BC4, 2-B1, 2-S2, 1-S3, 1-S4

- ▶ Attach the base B1 to part BC4 by using the locking pin
- ▶ Follow the number sequence
- ▶ Connect corner TC1 to BC4
- ▶ Connect S2 to TC1
- ▶ Connect S3 to S2
- ▶ Connect S4 to S3
- ▶ Connect S2 to S4
- ▶ Connect TC1 to S2
- ▶ Connect BC4 with Base to TC1

STEP 2:

PARTS REQUIRED: 2-C1, 2-C2

- ▶ Take Bottom Section from STEP 1
- ▶ Follow the number sequence
- ▶ Connect C1 to BC4
- ▶ Connect C2 to C1
- ▶ Repeat to complete other side

STEP 3:

PARTS REQUIRED: 2-TC1, 1-TC2, 2-C2, 2-C1, 3-S2

- ▶ Follow the number sequence
- ▶ Connect C1 to C2
- ▶ Connect TC1 to C2
- ▶ Connect S2 to TC1
- ▶ Connect S3 to S2
- ▶ Connect S4 to S3
- ▶ Connect S2 to S4
- ▶ Connect TC1 to S2
- ▶ Connect C1 to TC1
- ▶ Connect C1 to C2
- ▶ Attach the completed upper section to the lower section to complete the frame

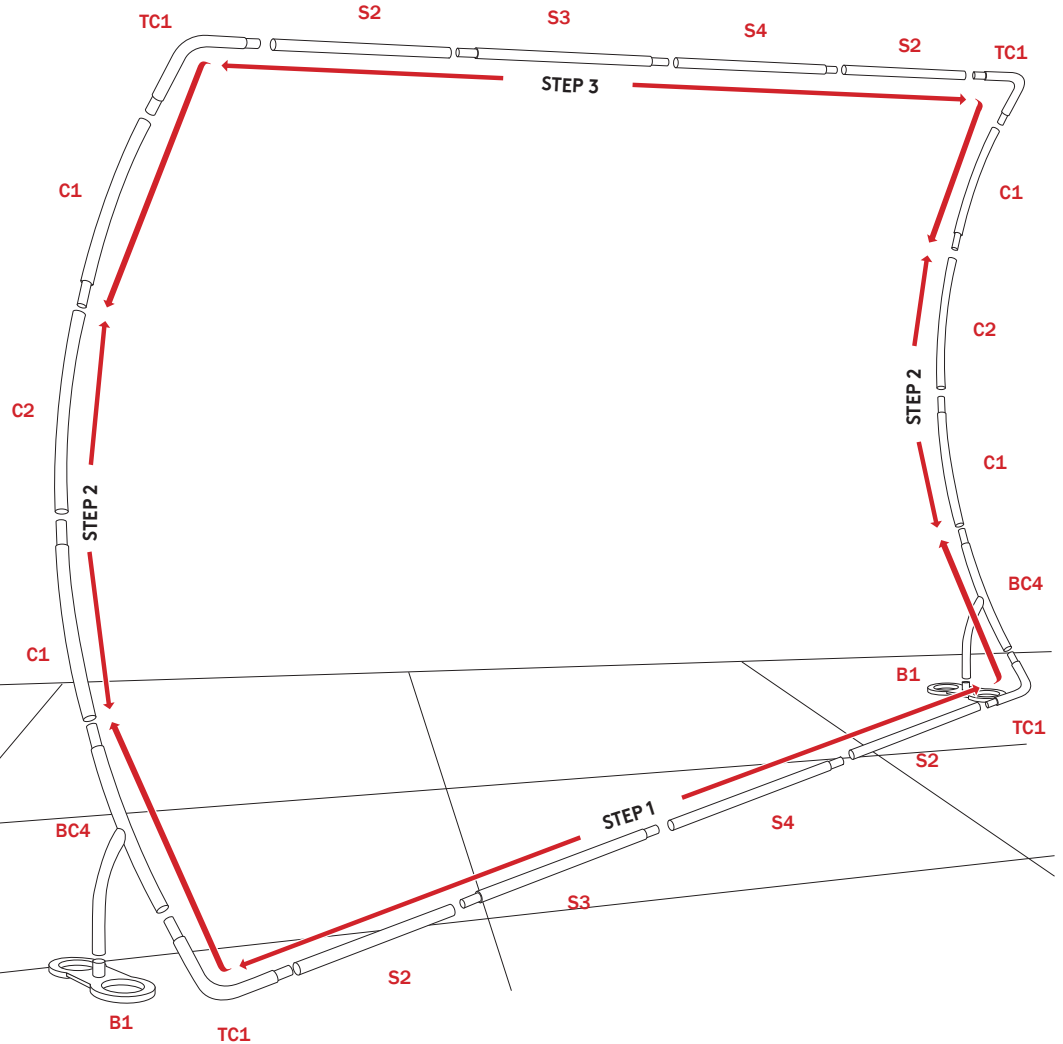

FABRIC INSTALLATION

- ▶ Make sure that floor is clean. If possible use a drop cloth. Lay frame on the floor
- ▶ Locate the opening on the fabric
- ▶ Make sure that zipper is open
- ▶ Drape fabric like a pillow cover to the frame starting at the top
- ▶ Pull the fabric part way down and stand frame up
- ▶ Pull fabric completely down and close zipper

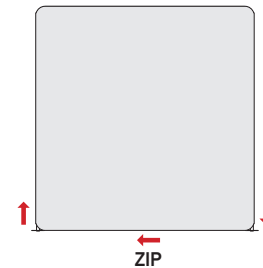
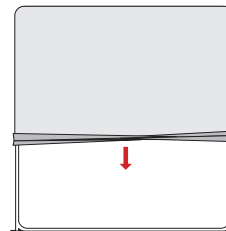
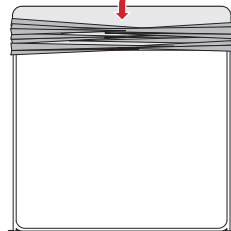

This document contains proprietary information. No portion may be disclosed to other, reproduced or used in any way without our written authorization.

©2018 McRae Imaging Inc.

SIZE SPECIFICATIONS:

72"W x 48"H

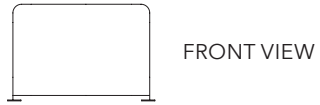

PARTS	CODE	QTY
	TC1	2
	P1	2
	P2	2
	P3	2
	BC1	2
	B1	2

FRAME ASSEMBLY

STEP 1: LOWER SECTION

PARTS REQUIRED: 2-BC1, 1-P1, 1-P2, 2-B1

- ▶ Attach the Base B1 to BC1 by pushing and turning until fully inserted
- ▶ Follow the number sequence
- ▶ Connect P2 to BC1
- ▶ Connect P1 to P2
- ▶ Connect P1 to BC1

STEP 2:

PARTS REQUIRED: 2-TC1, 1-P1, 1-P2

- ▶ Follow the number sequence
- ▶ Connect TC1 to P2
- ▶ Connect P2 to P1
- ▶ Connect P1 to TC1

STEP 3:

PARTS REQUIRED: Assembly from Step 1 & 2, 2-P3

- ▶ Connect P3 to TC1
- ▶ Connect P3 to BC1
- ▶ Repeat to complete the other side to complete the frame

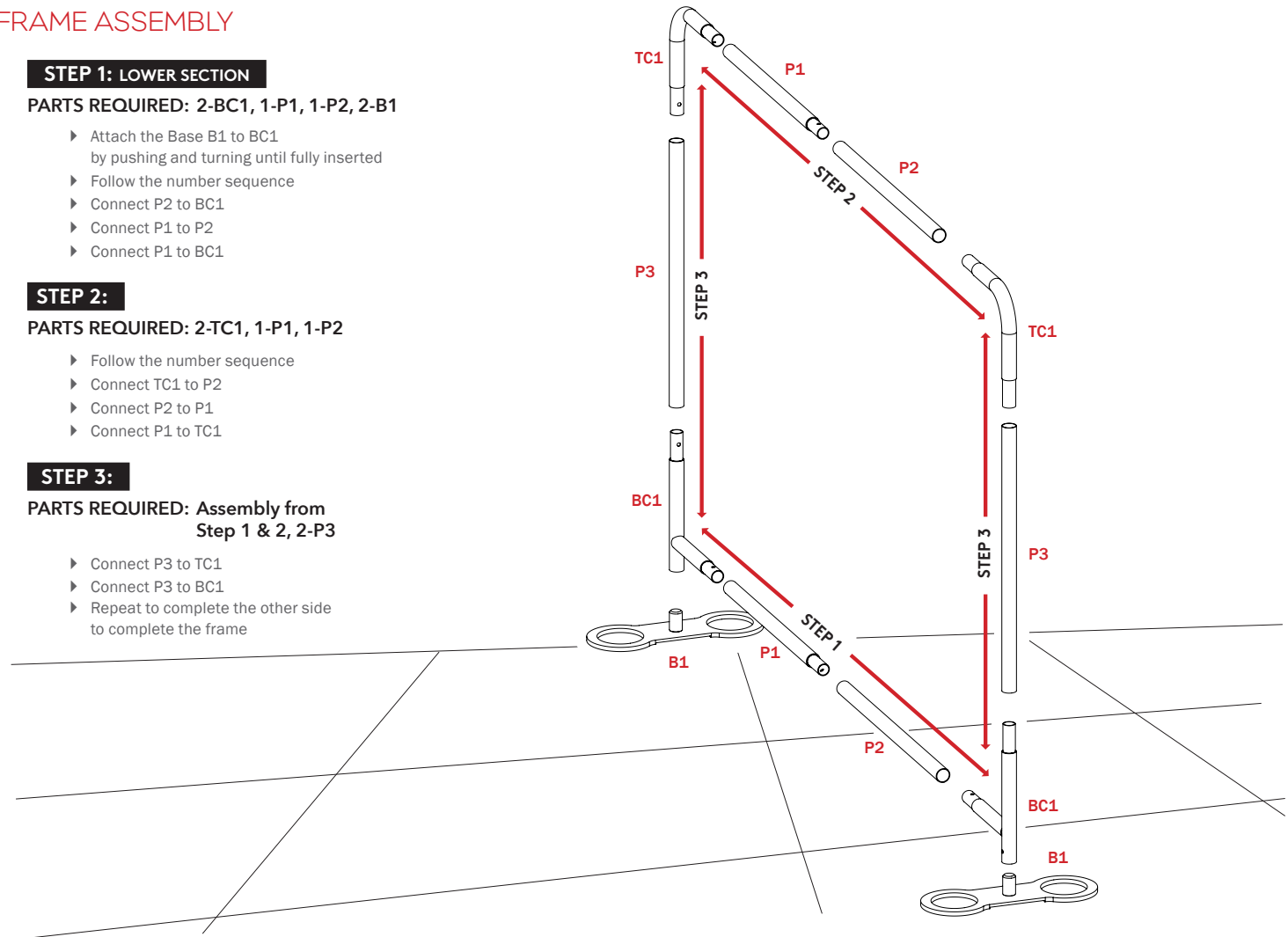

FABRIC INSTALLATION

- ▶ Make sure that floor is clean. If possible use a drop cloth. Lay frame on the floor
- ▶ Locate the opening on the fabric
- ▶ Make sure that zipper is open
- ▶ Drape fabric like a pillow cover to the frame starting at the top
- ▶ Pull the fabric part way down and stand frame up
- ▶ Pull fabric completely down and close zipper

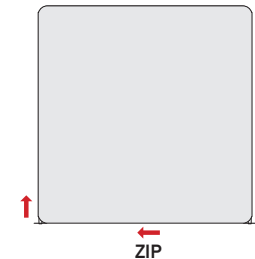
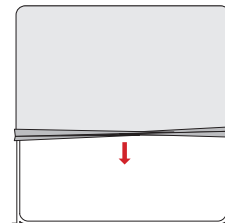
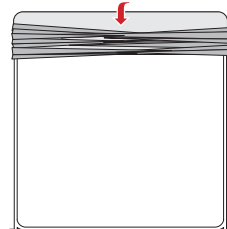

This document contains proprietary information. No portion may be disclosed to other, reproduced or used in any way without our written authorization.

©2018 McRae Imaging Inc.

SIZE SPECIFICATIONS:

115" W x 97.5" H

THIS INSTRUCTION SHEET IS APPLICABLE FOR 10 FT. MILAN ARC W. KIOSK.



FRONT VIEW



SIDE VIEW



ISOMETRIC VIEW

PARTS	CODE	QTY
	KBC1	2
	KS1	2
	KS2	2
	KS3	1
	KC1	2
	KC2	2
	KTC1	2
	KSB1	1
	KSH1	1

FRAME ASSEMBLY

STEP 1: LOWER SECTION

PARTS REQUIRED: 2-KBC1, 1-KS2

- ▶ Connect KBC1 to KS2 for each side

STEP 2:

PARTS REQUIRED: 2-KS1, 1-KSB1

- ▶ Take Lower Section from STEP 1
- ▶ Connect KS1 to KBC1 for each side
- ▶ Connect KSB1 to KS1 with bolts for each side

STEP 3:

PARTS REQUIRED: 2-KC1, 2-KC2, KS3

- ▶ Take Lower Section from STEP 2
- ▶ Connect KC1 to KS1 for each side
- ▶ Connect KS3 to KC1 with bolts for each side
- ▶ Connect KC2 to KC1 for each side

STEP 4:

PARTS REQUIRED: 2-KTC1, 1-KS2, KSH1

- ▶ Connect KTC1 to KS2 for each side
- ▶ Attach the completed upper section to the lower section
- ▶ Place KSH1 on top of KSB1 to complete the frame

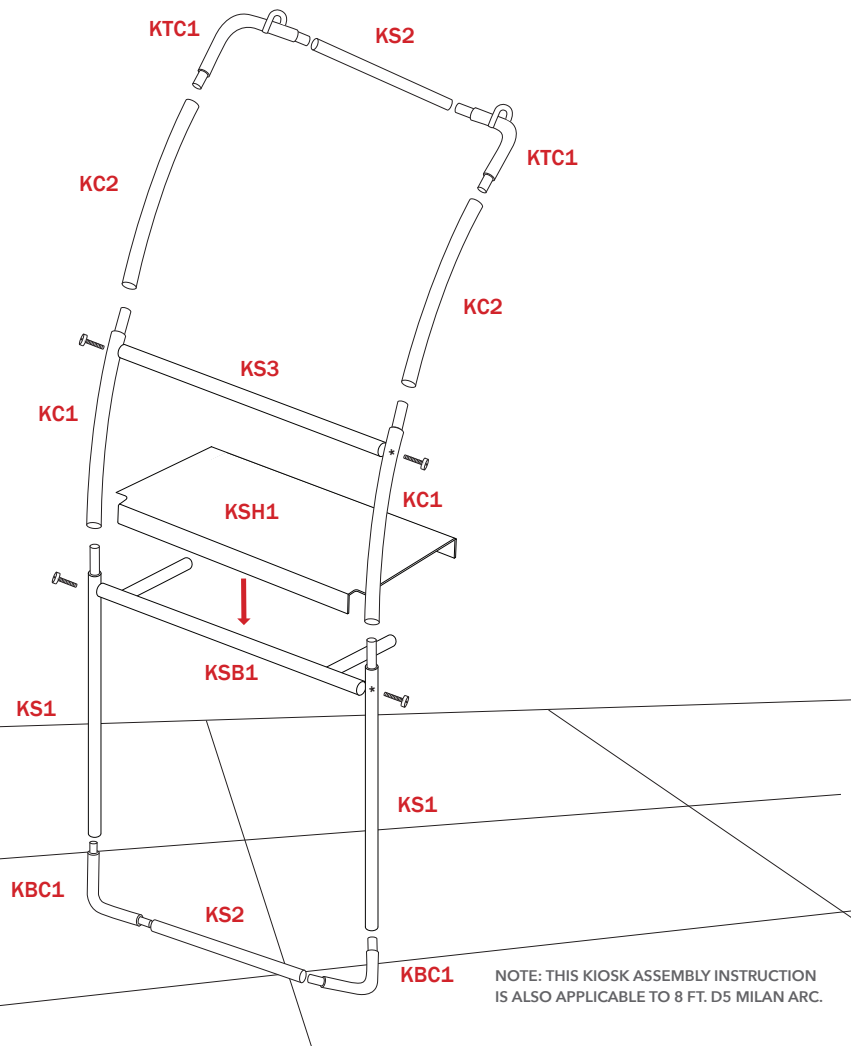

FABRIC INSTALLATION

- ▶ Make sure that floor is clean. If possible use a drop cloth. Lay frame on the floor
- ▶ Locate the opening on the fabric
- ▶ Make sure that zipper is open
- ▶ Drape fabric like a pillow cover to the frame starting at the top
- ▶ Pull the fabric part way down and stand frame up
- ▶ Pull fabric completely down and close zipper

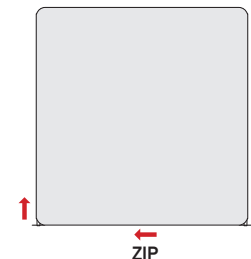
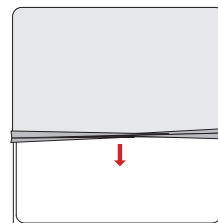
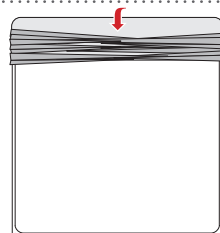

This document contains proprietary information. No portion may be disclosed to other, reproduced or used in any way without our written authorization.

©2018 McRae Imaging Inc.

SIZE SPECIFICATIONS:

115" W x 97.5" H

THIS INSTRUCTION SHEET IS APPLICABLE FOR 10 FT. MILAN ARC W. ELIPSE.



FRONT VIEW



SIDE VIEW

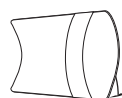

ISOMETRIC VIEW

PARTS	CODE	QTY
-------	------	-----

	EBC1	2
	ES2	2
	EC1	2
	EC2	4
	EC3	2
	ETC1	2

FRAME ASSEMBLY

STEP 1: LOWER SECTION

PARTS REQUIRED: 2-EBC1, 1-ES2

- ▶ Connect EBC1 to ES2 for each side

STEP 2:

PARTS REQUIRED: 2-EC1, 2-EC2

- ▶ Take Lower Section from STEP 1
- ▶ Connect EC1 to EBC1 for each side
- ▶ Connect EC2 to EBC1 for each side

STEP 3:

PARTS REQUIRED: 2-EC2, 2-EC3

- ▶ Take Lower Section from STEP 2
- ▶ Connect EC3 to EC2 for each side
- ▶ Connect another EC2 to EC3 for each side

STEP 4:

PARTS REQUIRED: 2-ETC1, 1-ES2

- ▶ Connect ETC1 to ES2 for each side
- ▶ Attach the completed upper section to the lower section to complete the frame

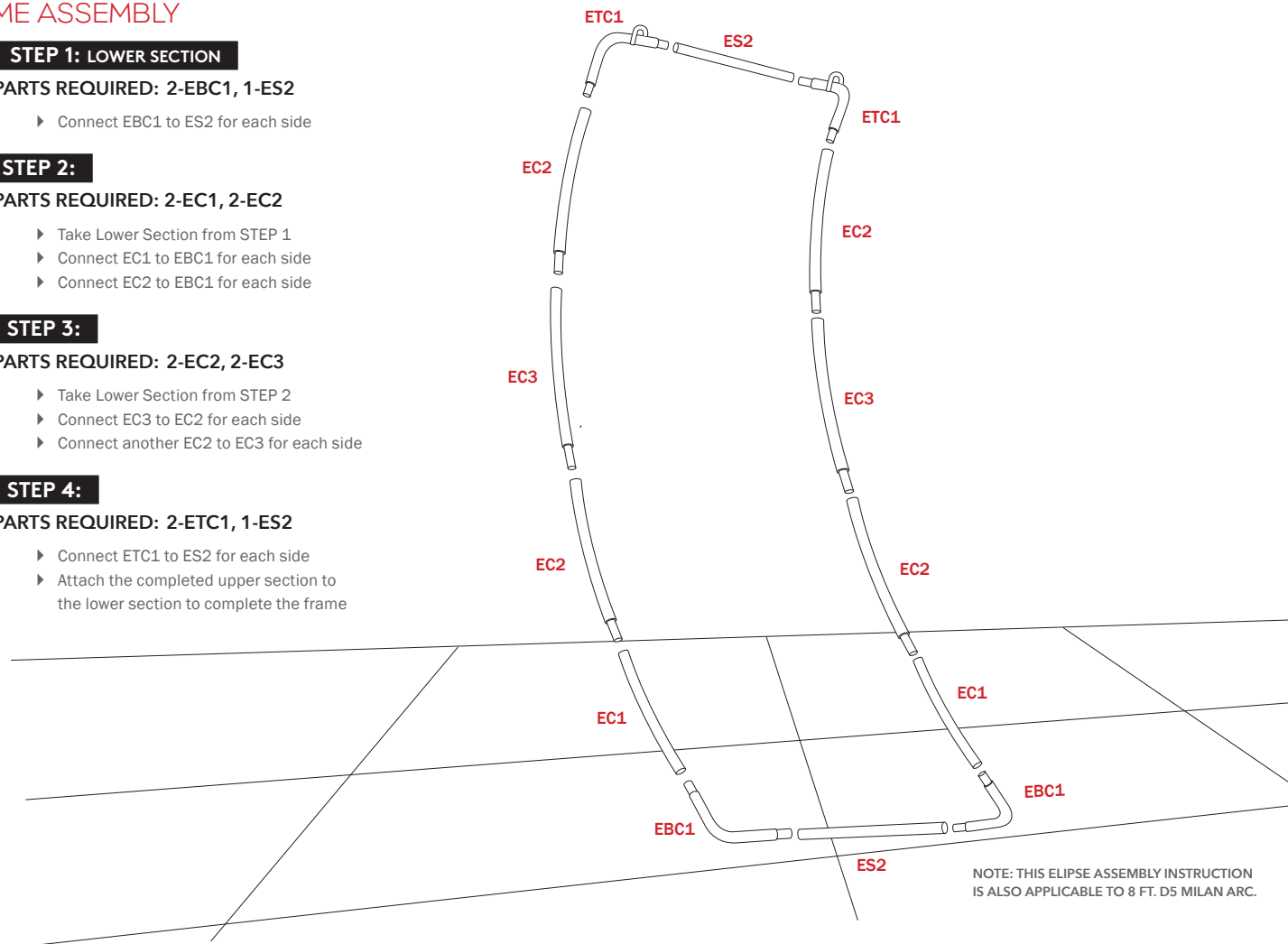

NOTE: THIS ELIPSE ASSEMBLY INSTRUCTION IS ALSO APPLICABLE TO 8 FT. D5 MILAN ARC.

FABRIC INSTALLATION

- ▶ Make sure that floor is clean. If possible use a drop cloth. Lay frame on the floor
- ▶ Locate the opening on the fabric
- ▶ Make sure that zipper is open
- ▶ Drape fabric like a pillow cover to the frame starting at the top
- ▶ Pull the fabric part way down and stand frame up
- ▶ Pull fabric completely down and close zipper

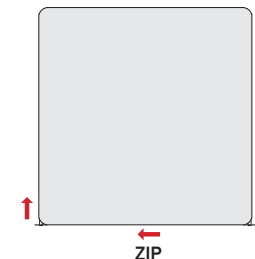
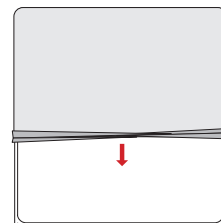
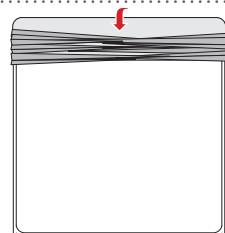

This document contains proprietary information. No portion may be disclosed to other, reproduced or used in any way without our written authorization.

©2018 McRae Imaging Inc.

SIZE SPECIFICATIONS:

115" W x 97.5" H

THIS INSTRUCTION SHEET IS APPLICABLE FOR 10 FT. MILAN ARC W. WALKTHROUGH.



FRONT VIEW



SIDE VIEW



ISOMETRIC VIEW

FRAME ASSEMBLY

STEP 1: LOWER SECTION

PARTS REQUIRED: 2-WBC1, 1-WS2

- ▶ Connect WBC1 to WS2 for each side

STEP 2:

PARTS REQUIRED: 2-WS1, 2-WC1, 2-WC2

- ▶ Take Lower Section from STEP 1
- ▶ Connect WS1 to WBC1 for each side
- ▶ Connect WC1 to WS1 for each side
- ▶ Connect WC2 to WC1 for each side

STEP 3:

PARTS REQUIRED: 2-WTC1, 1-WS2

- ▶ Connect WTC1 to WS2 for each side
- ▶ Attach the completed upper section to the lower section to complete the frame

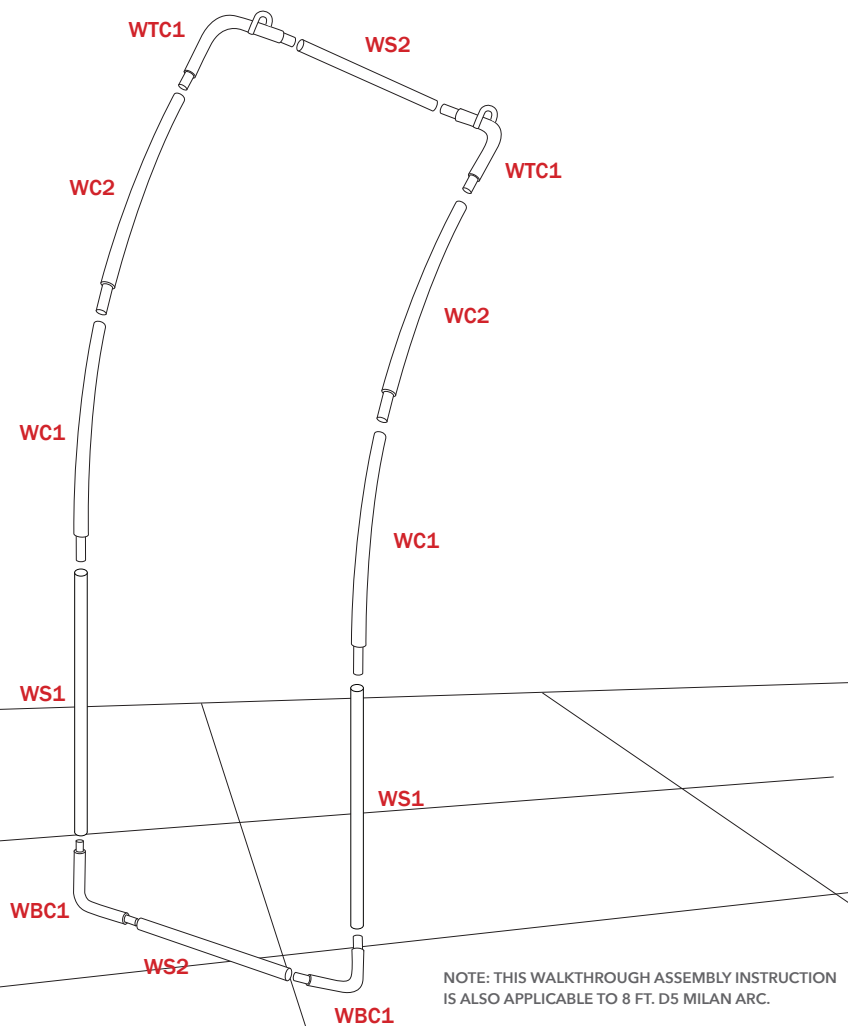

NOTE: THIS WALKTHROUGH ASSEMBLY INSTRUCTION IS ALSO APPLICABLE TO 8 FT. D5 MILAN ARC.

PARTS	CODE	QTY
-------	------	-----

	WBC1	2
	WS1	2
	WS2	2
	WC1	2
	WC2	2
	WTC1	2

FABRIC INSTALLATION

- ▶ Make sure that floor is clean. If possible use a drop cloth. Lay frame on the floor
- ▶ Locate the opening on the fabric
- ▶ Make sure that zipper is open
- ▶ Drape fabric like a pillow cover to the frame starting at the top
- ▶ Pull the fabric part way down and stand frame up
- ▶ Pull fabric completely down and close zipper

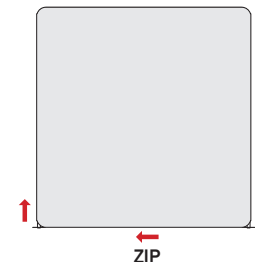
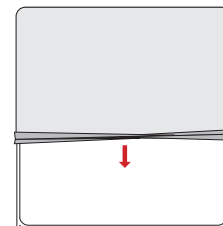
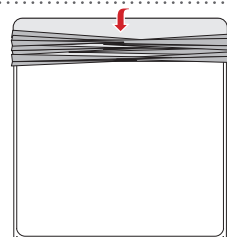

This document contains proprietary information. No portion may be disclosed to other, reproduced or used in any way without our written authorization.

©2018 McRae Imaging Inc.

THIS INSTRUCTION SHEET IS APPLICABLE FOR ALL FABRIC MURAL SIZES.

SIZES:

- 1x3:** 31"W x 88.5"H
- 2x2:** 59.5"W x 59.5"H
- 2x3:** 59.5"W x 88.5"H
- 3x3:** 88.5"W x 88.5"H
- 4x3:** 117"W x 88.5"H
- ENDCAPS:** 12.5"W x 88.5"H

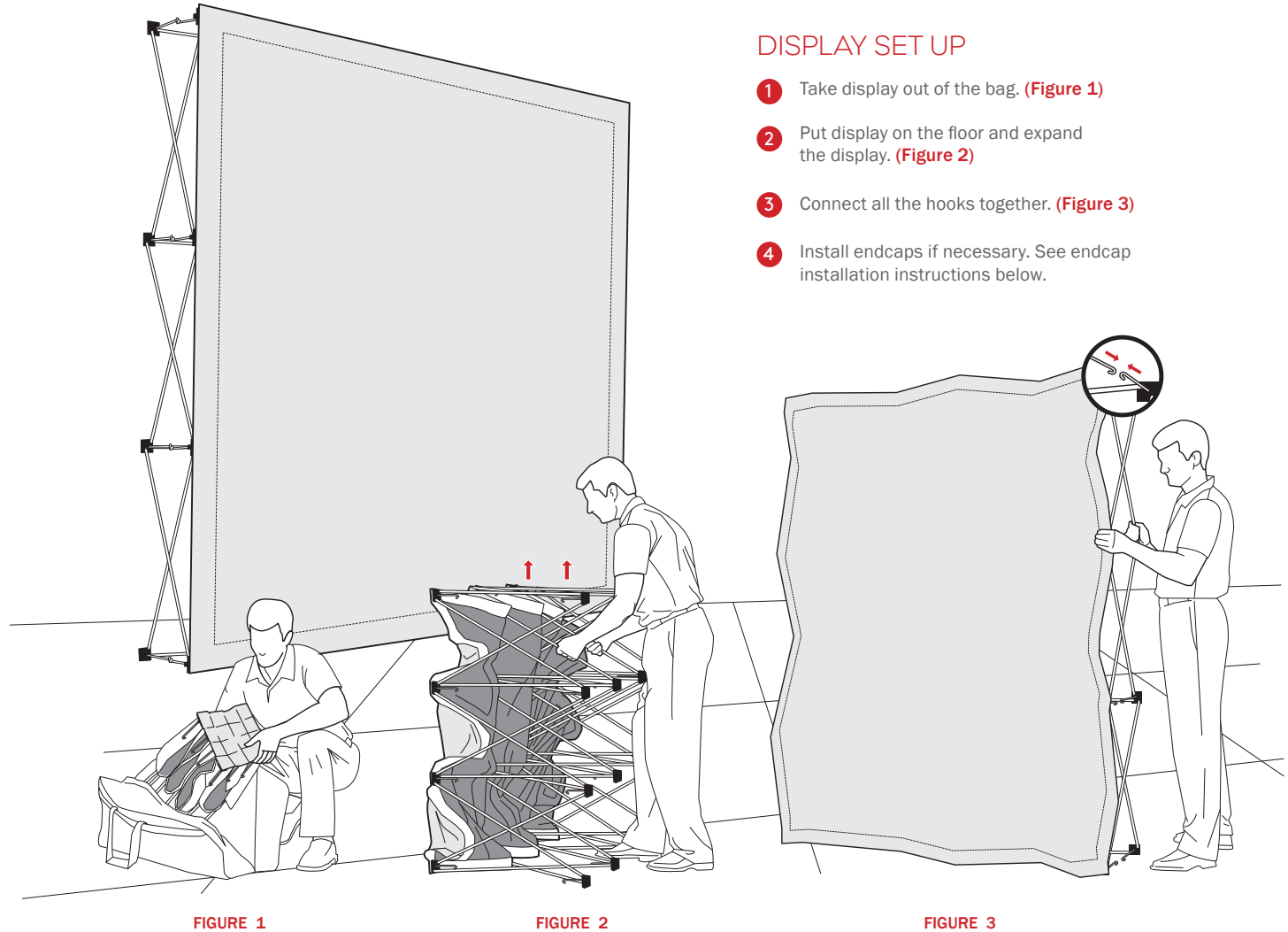

DISPLAY SET UP

- 1** Take display out of the bag. (Figure 1)
- 2** Put display on the floor and expand the display. (Figure 2)
- 3** Connect all the hooks together. (Figure 3)
- 4** Install endcaps if necessary. See endcap installation instructions below.

ENDCAP INSTALLATION

- 1** Attach top corner of the endcap to the top mount
- 2** Attach bottom corner of the endcap to the bottom mount
- 3** Attach the side of the endcap to the side mounts
- 4** Do the same thing to the other side

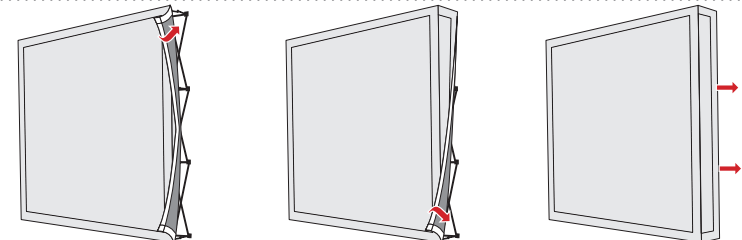

This document contains proprietary information. No portion may be disclosed to other, reproduced or used in any way without our written authorization.

©2018 McRae Imaging Inc.

THIS INSTRUCTION SHEET IS APPLICABLE FOR ALL RETRACTABLE BANNERS

DISPLAY SET UP

- 1 Take display out of the bag.
- 2 Put display on the floor and assemble pole. (Figure 1)
- 3 Insert pole into slot. (Figure 2)
- 4 Tilt unit with pole towards you and then pull graphic out and up to connector at top of pole. (Figure 3)

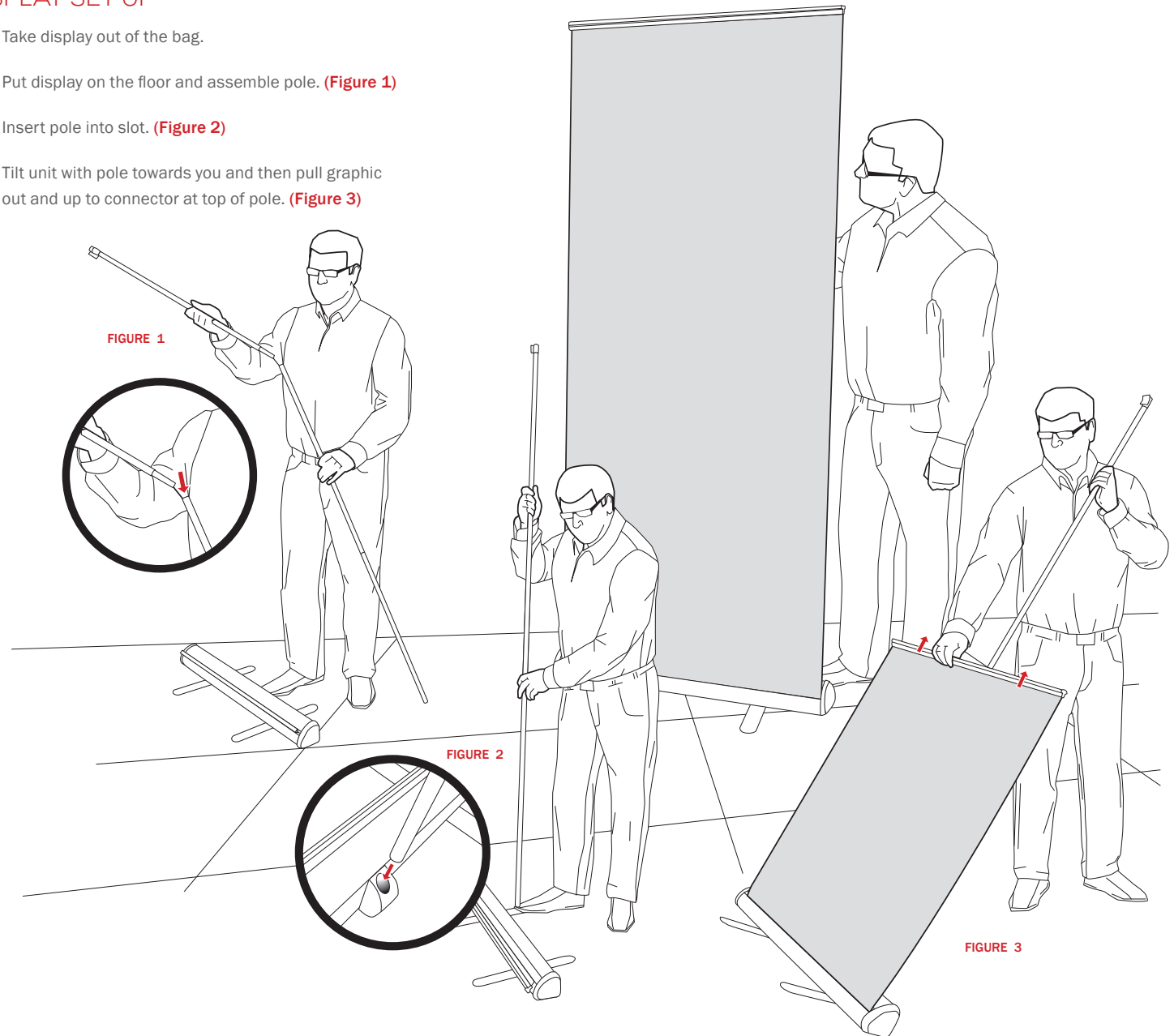

This document contains proprietary information. No portion may be disclosed to other, reproduced or used in any way without our written authorization.

©2018 McRae Imaging Inc.

SIZE SPECIFICATIONS:

FACE: 35"W x 88"H

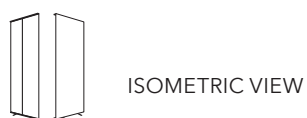

PARTS



CASE



TOP BAR

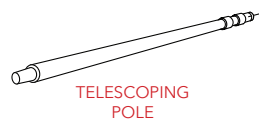

TELESCOPING POLE

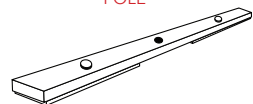

BASE BAR

This document contains proprietary information. No portion may be disclosed to other, reproduced or used in any way without our written authorization.

ASSEMBLY INSTRUCTIONS

- 1 Remove **QuickStand™** contents from the case – Telescoping Pole, Base Bar and Banner (attached to Top Bar).
- 2 Swing out the feet of the base bar and tighten the screws. Extend the Telescoping Pole half-way and twist the pole to lock it. **(Figure 1)**
- 3 Slide the bottom of the Telescoping Pole into the centre hole of the Base Bar. Rotate pole firmly to seat small pins into slots. **(Figure 2)**
- 4 Unroll the banner completely until the Top Bar is fully exposed. **(Figure 3)**
- 5 Insert the top of the Telescoping Pole in the centre hole located on the underside of the Top Bar. Unlock and extend the Telescoping Pole, leaving some slack in the banner. Apply bottom of banner to velcro on Base Bar. **(Figure 4)**
- 6 Extend the Telescoping Pole up until the banner is firm. Twist-lock into place the top portion of the pole. **(Figure 5)**

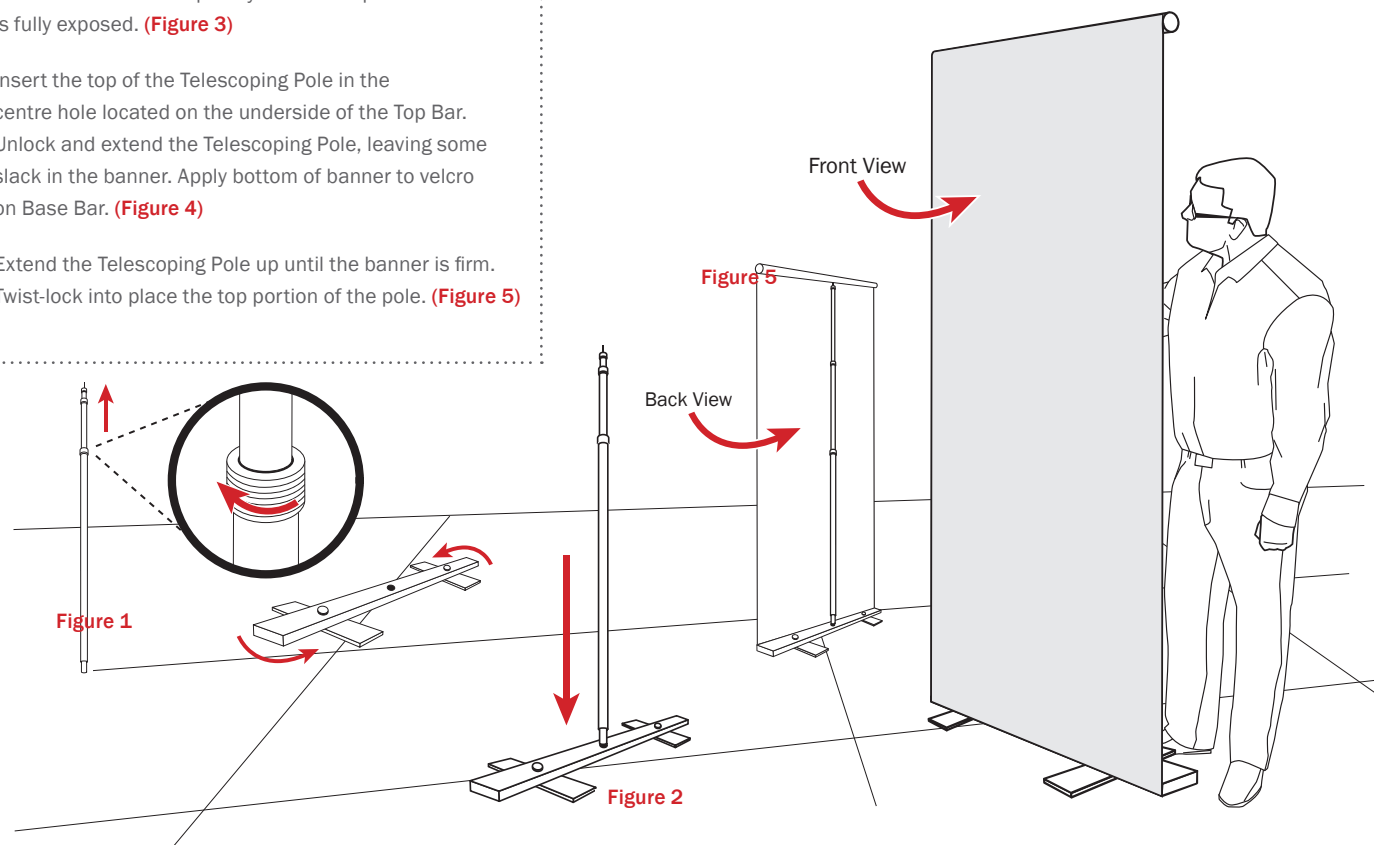
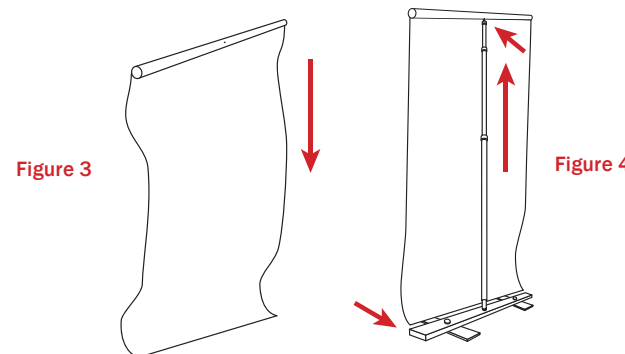



SIZE SPECIFICATIONS:

THIS INSTRUCTION SHEET IS APPLICABLE FOR 4 SEGMENT HALO SIZES.

HALO SIZES:

6' HALO

PARTS	QTY
 RING SEGMENT	4
 TOP RING SEGMENT WITH HANGING POINTS	4
 UPRIGHT	4

FRAME ASSEMBLY

STEP 1: BOTTOM RING

PARTS REQUIRED: 4 - BOTTOM RING SEGMENT

- ▶ Follow the number sequence
- ▶ Start building the bottom ring by connecting one bottom ring segment at a time.

STEP 2:

PARTS REQUIRED: 4 - UPRIGHTS

- ▶ Connect the Uprights to the bottom ring

STEP 3: UPPER RING AND FRAME

PARTS REQUIRED: 4 - UPPER RING SEGMENT

- ▶ Follow the number sequence
- ▶ Start building the upper ring by connecting one bottom ring segment at a time.
- ▶ Connect the upper ring to the uprights.

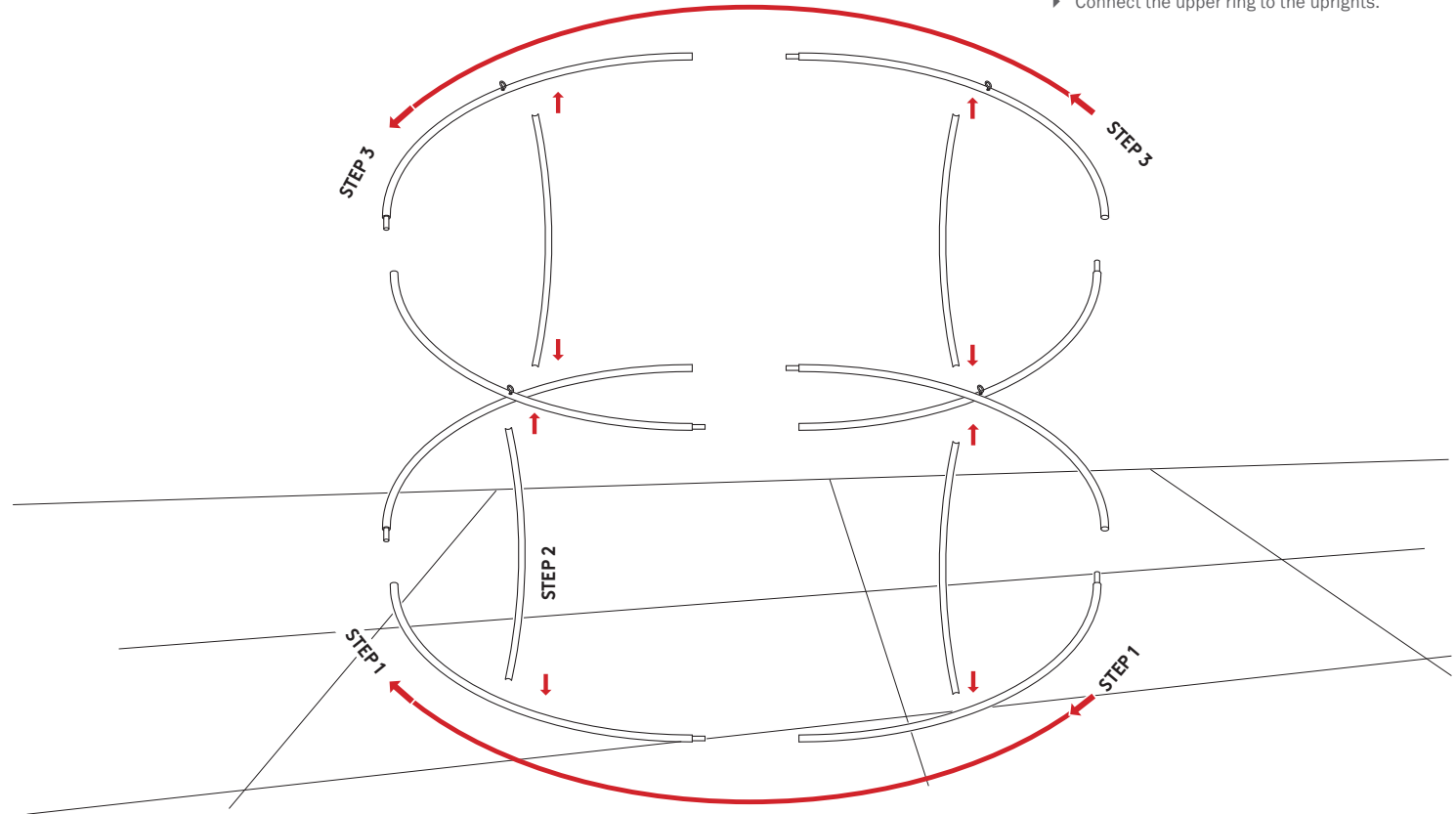

FABRIC INSTALLATION

- ▶ Make sure work area is clean of dirt and other materials that might damage or dirty the fabric. Use a drop cloth if possible & never use newsprint
- ▶ Put unzip fabric on the floor and open up the fabric.
- ▶ Put frame on top of fabric, make sure to match the button holes to the hanging points
- ▶ Pull the outside and inside fabric up and close zippers

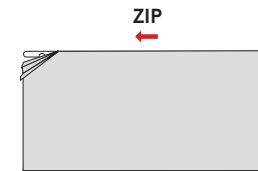
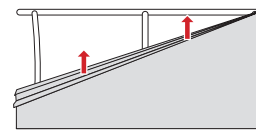
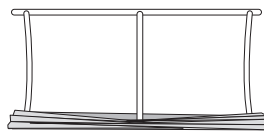

This document contains proprietary information. No portion may be disclosed to other, reproduced or used in any way without our written authorization.



©2018 McRae Imaging Inc.

SIZE SPECIFICATIONS:

THIS INSTRUCTION SHEET IS APPLICABLE FOR 6 SEGMENT HALO SIZES.

HALO SIZES:

8' HALO
10' HALO

PARTS	QTY
 RING SEGMENT	8
 TOP RING SEGMENT WITH HANGING POINTS	4
 UPRIGHT	6

FRAME ASSEMBLY

STEP 1: BOTTOM RING

PARTS REQUIRED: 6 - BOTTOM RING SEGMENT

- ▶ Follow the number sequence
- ▶ Start building the bottom ring by connecting one bottom ring segment at a time.

STEP 2:

PARTS REQUIRED: 6 - UPRIGHTS

- ▶ Connect the Uprights to the bottom ring

STEP 3: UPPER RING AND FRAME

PARTS REQUIRED: 6 - UPPER RING SEGMENT

- ▶ Follow the number sequence
- ▶ Start building the upper ring by connecting one bottom ring segment at a time.
- ▶ Connect the upper ring to the uprights.

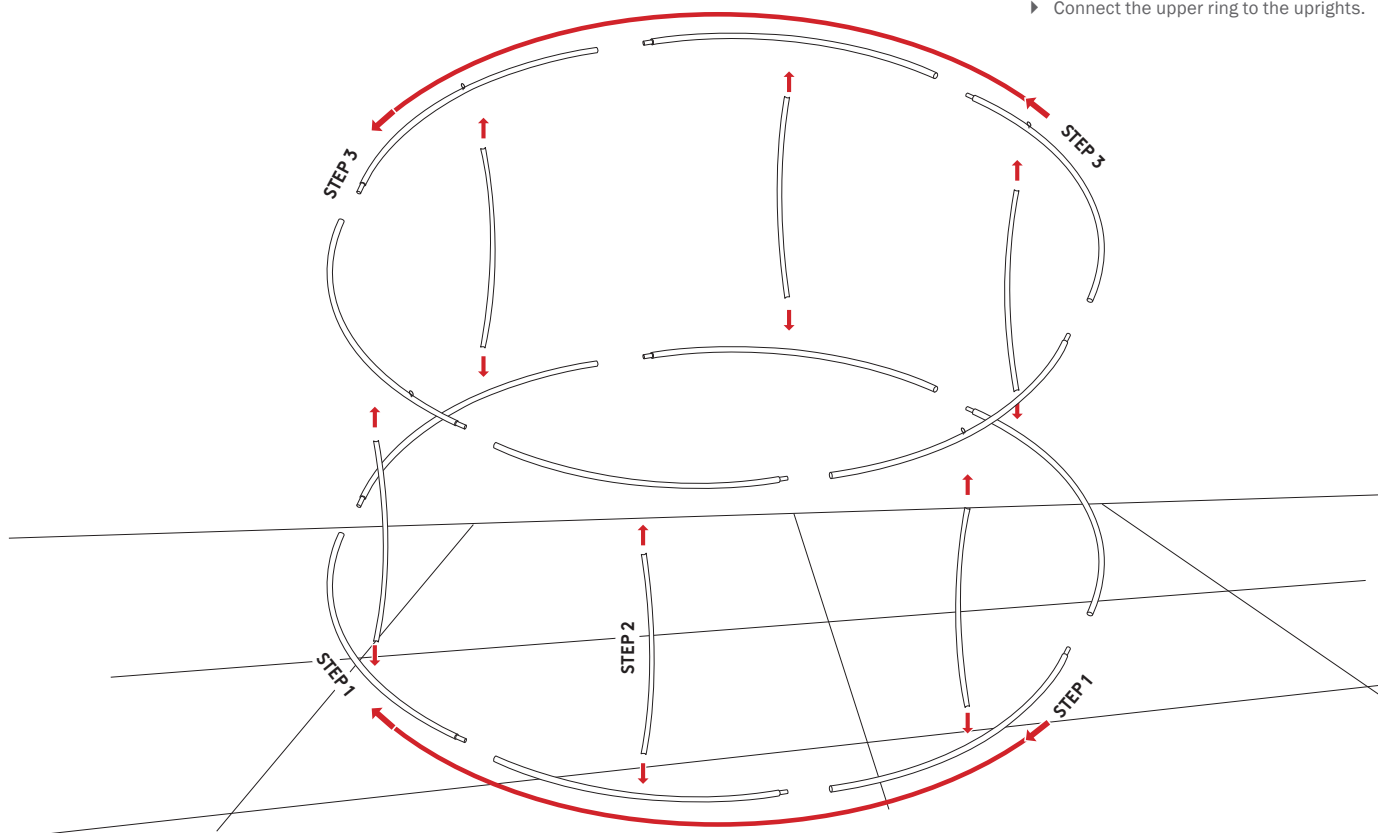

FABRIC INSTALLATION

- ▶ Make sure work area is clean of dirt and other materials that might damage or dirty the fabric. Use a drop cloth if possible & never use newsprint
- ▶ Put unzip fabric on the floor and open up the fabric.
- ▶ Put frame on top of fabric, make sure to match the button holes to the hanging points
- ▶ Pull the outside and inside fabric up and close zippers

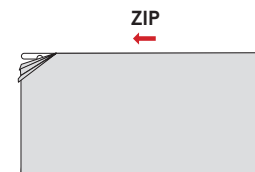
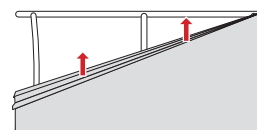
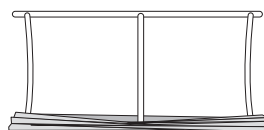

This document contains proprietary information. No portion may be disclosed to other, reproduced or used in any way without our written authorization.



©2018 McRae Imaging Inc.

SIZE SPECIFICATIONS:

THIS INSTRUCTION SHEET IS APPLICABLE FOR 8 SEGMENT HALO SIZES.

HALO SIZES:

12' HALO
14' HALO

PARTS	QTY
 RING SEGMENT	12
 TOP RING SEGMENT WITH HANGING POINTS	4
 UPRIGHT	8

FRAME ASSEMBLY

STEP 1: BOTTOM RING

PARTS REQUIRED: 8 - BOTTOM RING SEGMENT

- ▶ Follow the number sequence
- ▶ Start building the bottom ring by connecting one bottom ring segment at a time.

STEP 2:

PARTS REQUIRED: 8 - UPRIGHTS

- ▶ Connect the Uprights to the bottom ring

STEP 3: UPPER RING AND FRAME

PARTS REQUIRED: 8 - UPPER RING SEGMENT

- ▶ Follow the number sequence
- ▶ Start building the upper ring by connecting one bottom ring segment at a time.
- ▶ Connect the upper ring to the uprights.

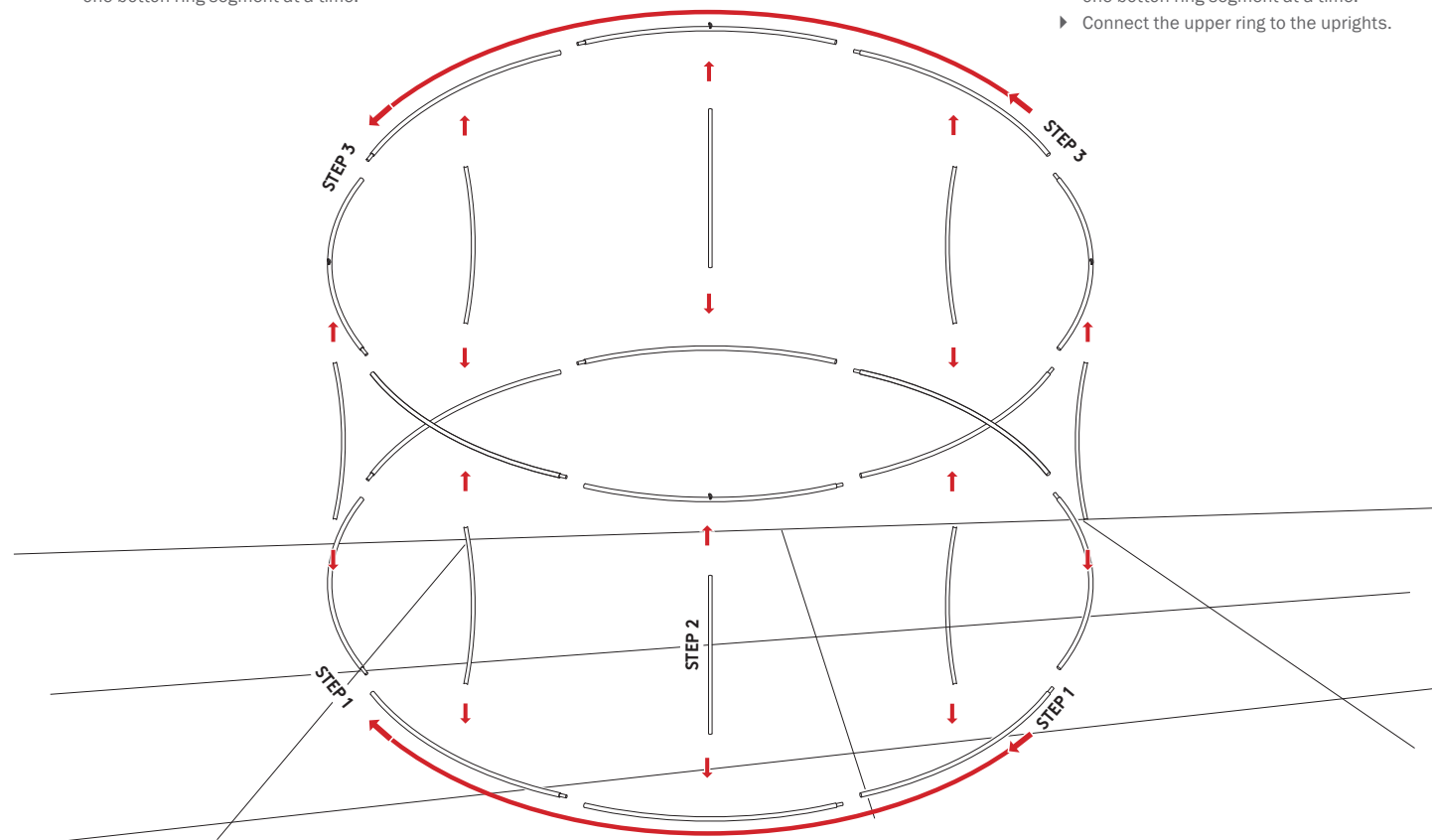

FABRIC INSTALLATION

- ▶ Make sure work area is clean of dirt and other materials that might damage or dirty the fabric. Use a drop cloth if possible & never use newsprint
- ▶ Put unzip fabric on the floor and open up the fabric.
- ▶ Put frame on top of fabric, make sure to match the button holes to the hanging points
- ▶ Pull the outside and inside fabric up and close zippers

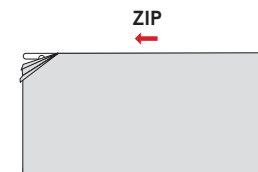
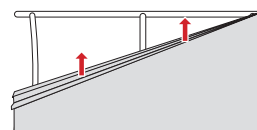
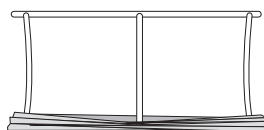

This document contains proprietary information. No portion may be disclosed to other, reproduced or used in any way without our written authorization.



©2018 McRae Imaging Inc.

SIZE SPECIFICATIONS:

THIS INSTRUCTION SHEET IS APPLICABLE FOR 10 SEGMENT HALO SIZES.

HALO SIZES:

18' HALO

PARTS	QTY
 RING SEGMENT	15
 TOP RING SEGMENT WITH HANGING POINTS	5
 UPRIGHT	10

FRAME ASSEMBLY

STEP 1: BOTTOM RING

PARTS REQUIRED: 10 - BOTTOM RING SEGMENT

- ▶ Follow the number sequence
- ▶ Start building the bottom ring by connecting one bottom ring segment at a time.

STEP 2:

PARTS REQUIRED: 5 - UPRIGHTS

- ▶ Connect the Uprights to the bottom ring

STEP 3: UPPER RING AND FRAME

PARTS REQUIRED: 10 - UPPER RING SEGMENT

- ▶ Follow the number sequence
- ▶ Start building the upper ring by connecting one bottom ring segment at a time.
- ▶ Connect the upper ring to the uprights.

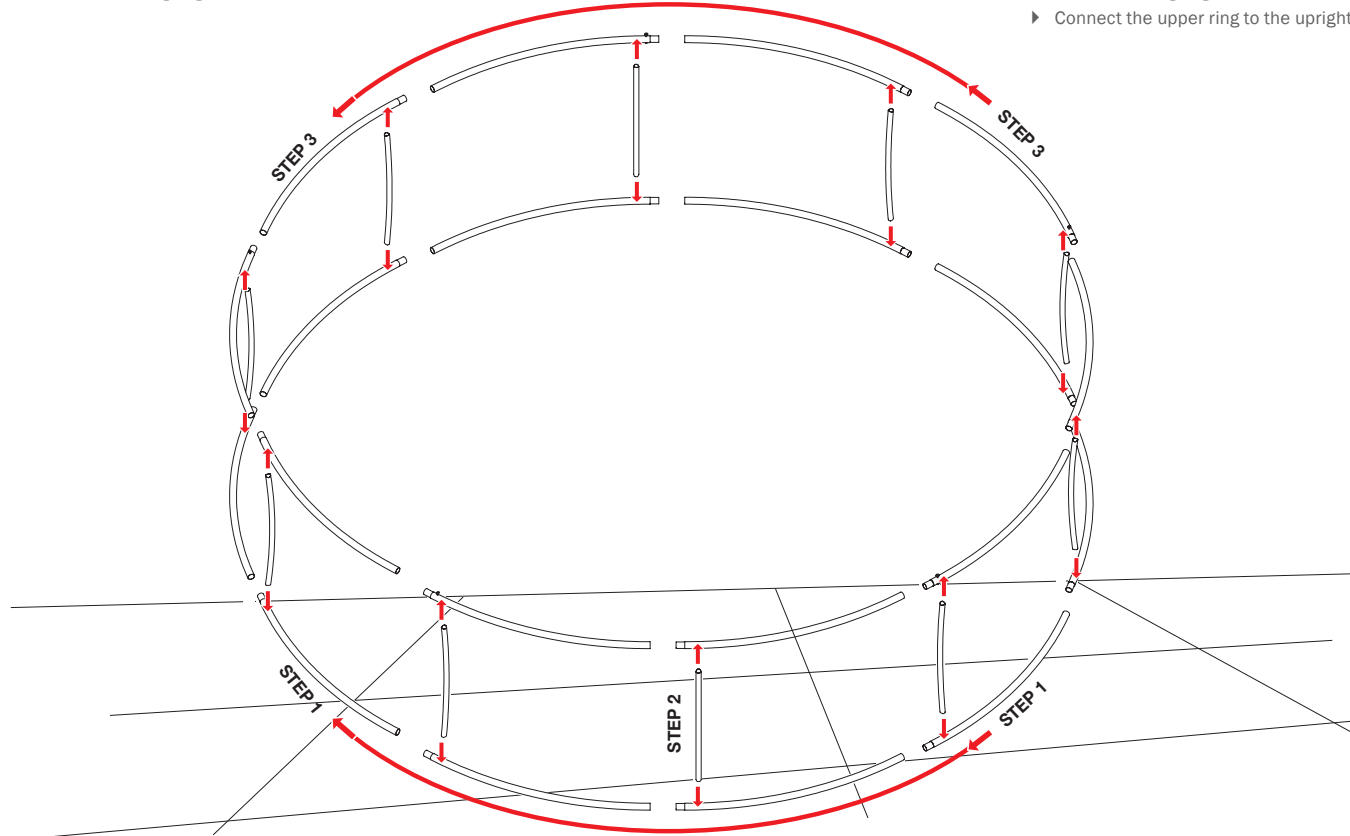

FABRIC INSTALLATION

- ▶ Make sure work area is clean of dirt and other materials that might damage or dirty the fabric. Use a drop cloth if possible & never use newsprint
- ▶ Put unzip fabric on the floor and open up the fabric.
- ▶ Put frame on top of fabric, make sure to match the button holes to the hanging points
- ▶ Pull the outside and inside fabric up and close zippers

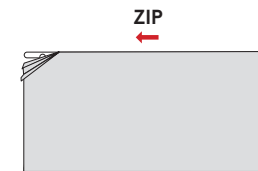
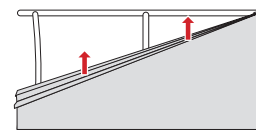
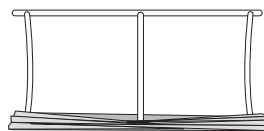

This document contains proprietary information. No portion may be disclosed to other, reproduced or used in any way without our written authorization.

©2018 McRae Imaging Inc.

SIZE SPECIFICATIONS:

THIS INSTRUCTION SHEET IS APPLICABLE FOR 12 SEGMENT HALO SIZES.

HALO SIZES:

20' HALO

FRAME ASSEMBLY

STEP 1: BOTTOM RING

PARTS REQUIRED: 12 - BOTTOM RING SEGMENT

- ▶ Follow the number sequence
- ▶ Start building the bottom ring by connecting one bottom ring segment at a time.

STEP 2:

PARTS REQUIRED: 6 - UPRIGHTS



- ▶ Connect the Uprights to the bottom ring

STEP 3: UPPER RING AND FRAME

PARTS REQUIRED: 12 - UPPER RING SEGMENT

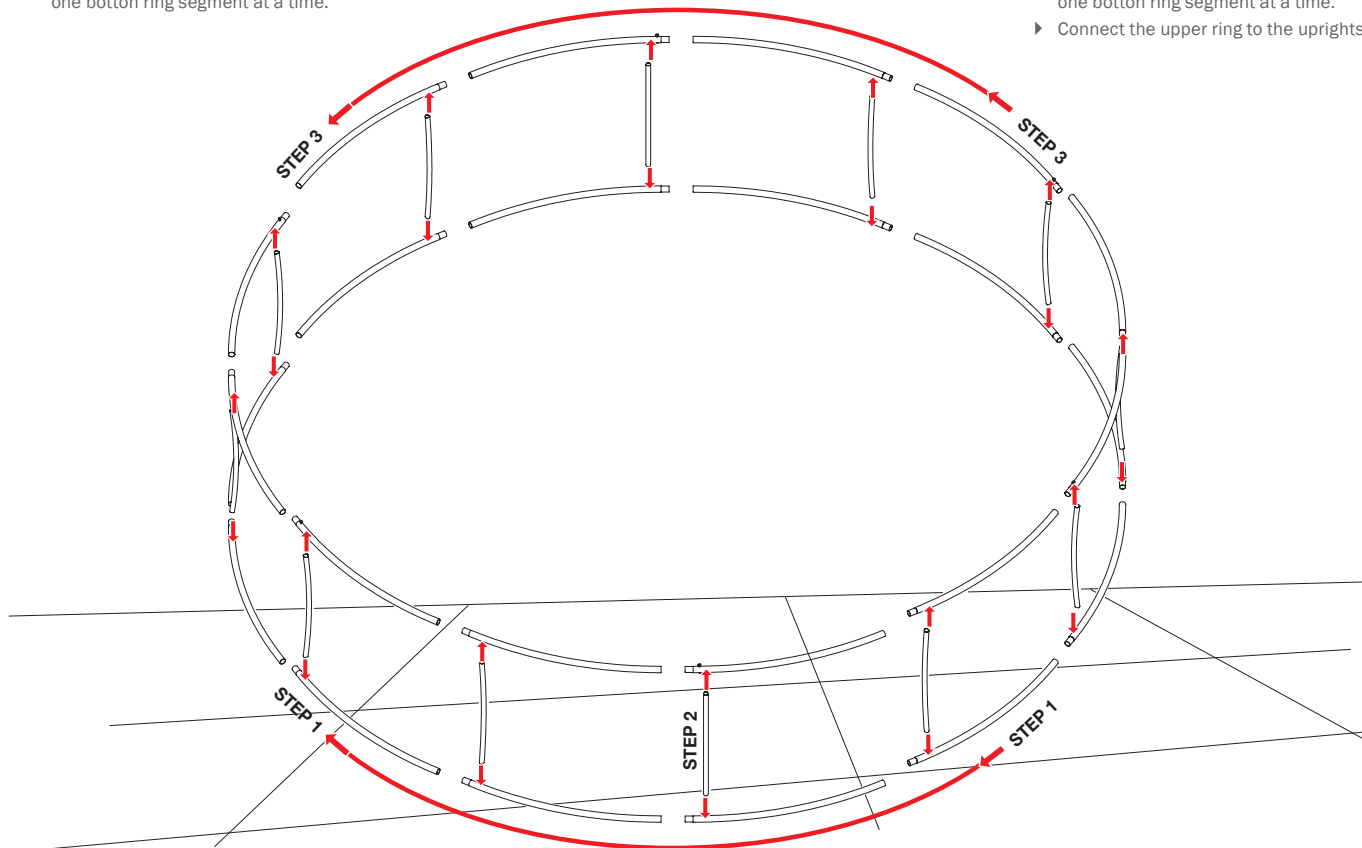
- ▶ Follow the number sequence
- ▶ Start building the upper ring by connecting one bottom ring segment at a time.
- ▶ Connect the upper ring to the uprights.



PARTS	QTY
 RING SEGMENT	18
 TOP RING SEGMENT WITH HANGING POINTS	6
 UPRIGHT	12

FABRIC INSTALLATION

- ▶ Make sure work area is clean of dirt and other materials that might damage or dirty the fabric. Use a drop cloth if possible & never use newsprint
- ▶ Put unzip fabric on the floor and open up the fabric.
- ▶ Put frame on top of fabric, make sure to match the button holes to the hanging points
- ▶ Pull the outside and inside fabric up and close zippers

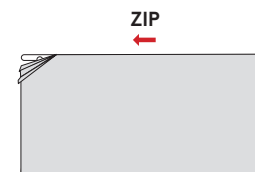
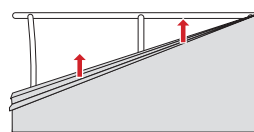

This document contains proprietary information. No portion may be disclosed to other, reproduced or used in any way without our written authorization.



©2018 McRae Imaging Inc.

SIZE SPECIFICATIONS:

THIS INSTRUCTION SHEET IS APPLICABLE FOR 14 SEGMENT HALO SIZES.

HALO SIZES:

24' HALO

PARTS	QTY
 RING SEGMENT	21
 TOP RING SEGMENT WITH HANGING POINTS	7
 UPRIGHT	14

FRAME ASSEMBLY

STEP 1: BOTTOM RING

PARTS REQUIRED: 14 - BOTTOM RING SEGMENTS

- ▶ Follow the number sequence
- ▶ Start building the bottom ring by connecting one bottom ring segment at a time

STEP 2:

PARTS REQUIRED: 14 - UPRIGHTS

- ▶ Connect the Uprights to the bottom ring

STEP 3: UPPER RING AND FRAME

PARTS REQUIRED: 7 - UPPER RING SEGMENTS & 7 - UPPER RING SEGMENTS With Hanging Points

- ▶ Follow the number sequence
- ▶ Start building the upper ring by connecting one bottom ring segment at a time
- ▶ Connect the upper ring to the uprights

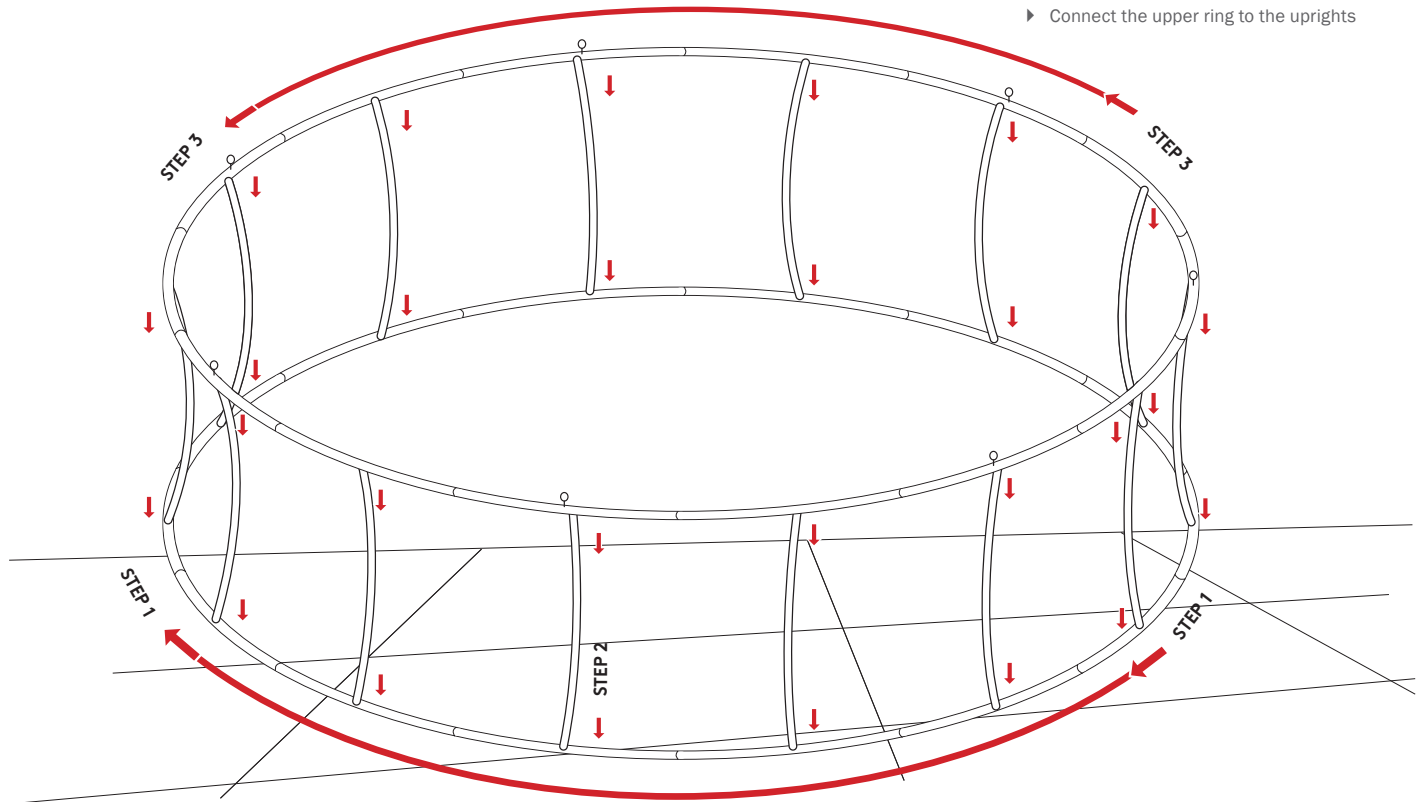

FABRIC INSTALLATION

- ▶ Make sure work area is clean of dirt and other materials that might damage or dirty the fabric. Use a drop cloth if possible & never use newsprint
- ▶ Put unzip fabric on the floor and open up the fabric.
- ▶ Put frame on top of fabric, make sure to match the button holes to the hanging points
- ▶ Pull the outside and inside fabric up and close zippers

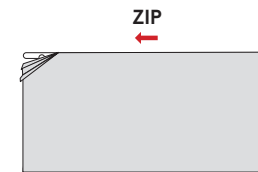
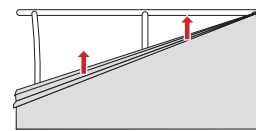
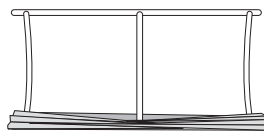

This document contains proprietary information. No portion may be disclosed to other, reproduced or used in any way without our written authorization.

©2018 McRae Imaging Inc.





SIZE SPECIFICATIONS:

THIS INSTRUCTION SHEET IS APPLICABLE FOR 6 SEGMENT BACKLIT HALO SIZES.

HALO SIZES:

08' HALO

10' HALO

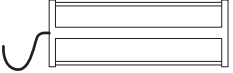
PARTS	QTY
 RING SEGMENT	8
 TOP RING SEGMENT WITH HANGING POINTS	4
 UPRIGHT	6
 CROSSBARS	6
 LIGHTS	6

FRAME ASSEMBLY

STEP 1: HALO SEGMENTS (6 Required)

PARTS REQUIRED: 1-Upright, 1- Bottom Segment
(NOTE: 4 out of 6 Top Segments have Hanging Points)

- ▶ Follow the number sequence
- ▶ Attach Upright to Bottom Segment
- ▶ Attach Top Segment to Upright
- ▶ Repeat Steps to complete 6 Segments

STEP 2:

PARTS REQUIRED: 6 - HALO SEGMENTS

- ▶ Follow the number sequence
- ▶ Connect All segments to one another
- ▶ Connect crossbars

STEP 3: LIGHTS

PARTS REQUIRED: 6 - LIGHTS

- ▶ Attach lights to crossbar using clamps provided
- ▶ Make sure that lights are facing outside
- ▶ Connect lights to one another

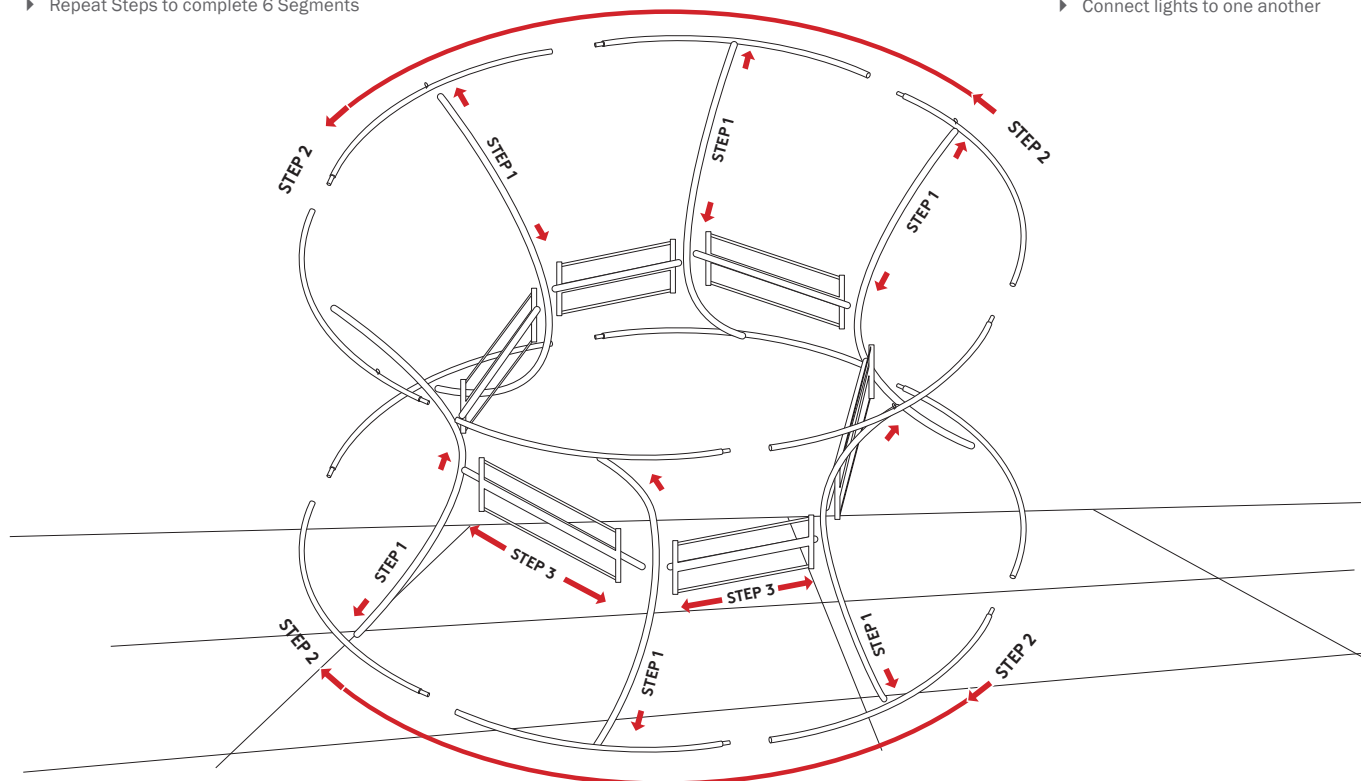

FABRIC INSTALLATION

- ▶ Make sure work area is clean of dirt and other materials that might damage or dirty the fabric. Use a drop cloth if possible & never use newsprint
- ▶ Put unzip fabric on the floor and open up the fabric.
- ▶ Put frame on top of fabric, make sure to match the button holes to the hanging points
- ▶ Pull the outside and inside fabric up and close zippers

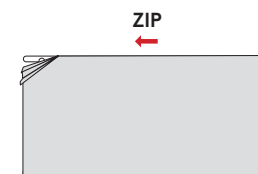
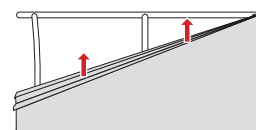
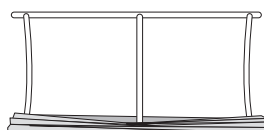

This document contains proprietary information. No portion may be disclosed to other, reproduced or used in any way without our written authorization.



©2018 McRae Imaging Inc.

SIZE SPECIFICATIONS:

THIS INSTRUCTION SHEET IS APPLICABLE FOR SQUARE HANGING SIGN.

FRAME ASSEMBLY

STEP 1: BOTTOM SECTION

PARTS REQUIRED:  (No Hanging Points) x4
 x4
 x4



- ▶ Follow the number sequence
- ▶ Start building the bottom section by connecting parts together

STEP 2:

PARTS REQUIRED:  x4
 x4





- ▶ Connect the uprights to bottom section

STEP 3: TOP SECTION AND FRAME

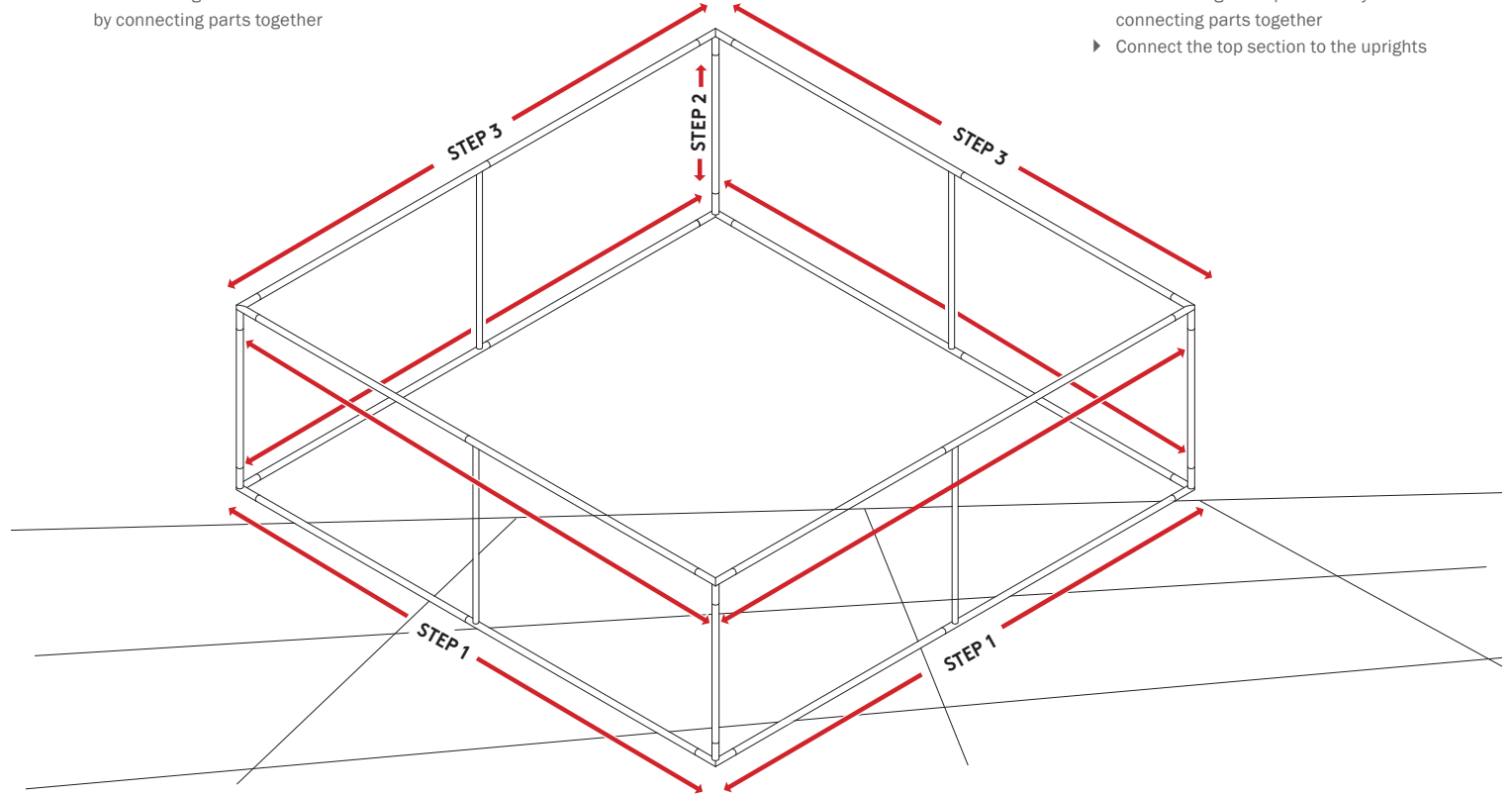
PARTS REQUIRED:  (With Hanging Points) x4
 x4
 x4

- ▶ Follow the number sequence
- ▶ Start building the top section by connecting parts together
- ▶ Connect the top section to the uprights



PARTS	QTY
 4 PCS. WITH HANGING POINTS	8
	8
	8
UPRIGHTS	
	4
	4

FABRIC INSTALLATION

- ▶ Make sure work area is clean of dirt and other materials that might damage or dirty the fabric. Use a drop cloth if possible & never use newsprint
- ▶ Put unzip fabric on the floor and open up the fabric.
- ▶ Put frame on top of fabric, make sure to match the button holes to the hanging points
- ▶ Pull the outside and inside fabric up and close zippers

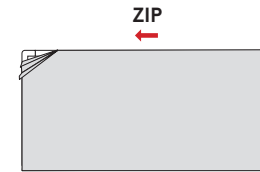
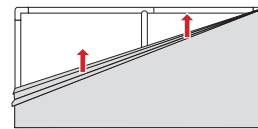
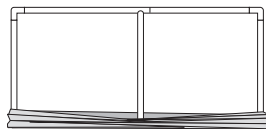

This document contains proprietary information. No portion may be disclosed to other, reproduced or used in any way without our written authorization.



©2018 McRae Imaging Inc.

SIZE SPECIFICATIONS:

THIS INSTRUCTION SHEET IS APPLICABLE FOR RECTANGLE HANGING SIGN.

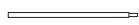

FRAME ASSEMBLY

STEP 1: BOTTOM SECTION

PARTS REQUIRED:  (No Hanging Points) x4
 x4
 x2

- ▶ Follow the number sequence
- ▶ Start building the bottom section by connecting parts together

STEP 2:

PARTS REQUIRED:  x4
 x2





- ▶ Connect the uprights to bottom section

STEP 3: TOP SECTION AND FRAME

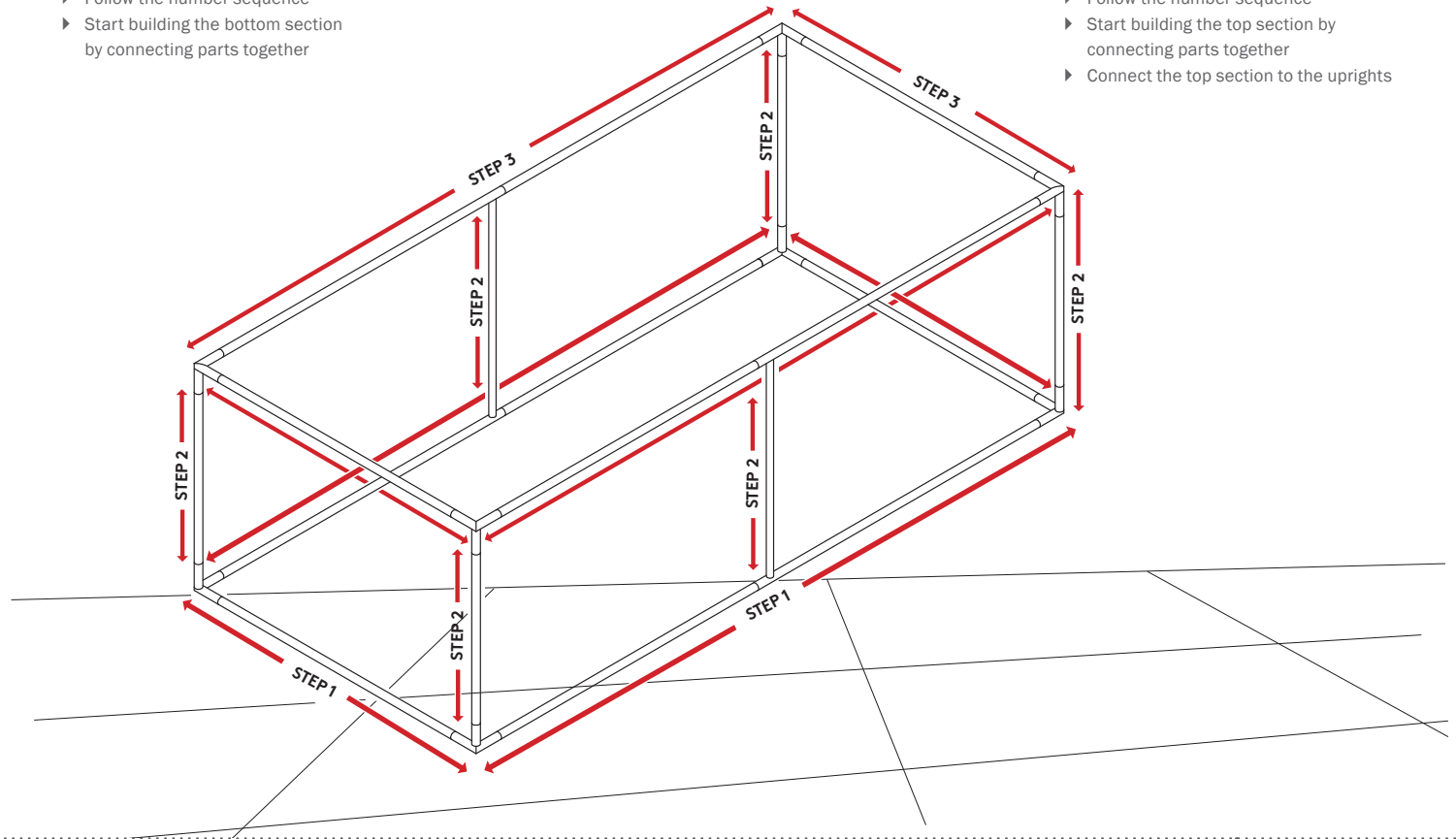
PARTS REQUIRED:  (With Hanging Points) x4
 x4
 x2

- ▶ Follow the number sequence
- ▶ Start building the top section by connecting parts together
- ▶ Connect the top section to the uprights



PARTS	QTY
 4 PCS. WITH HANGING POINTS	8
	8
	6
UPRIGHTS	
	2
	2

FABRIC INSTALLATION

- ▶ Make sure work area is clean of dirt and other materials that might damage or dirty the fabric. Use a drop cloth if possible & never use newsprint
- ▶ Put unzip fabric on the floor and open up the fabric.
- ▶ Put frame on top of fabric, make sure to match the button holes to the hanging points
- ▶ Pull the outside and inside fabric up and close zippers

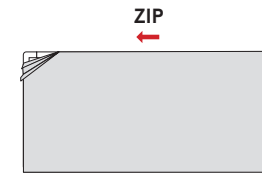
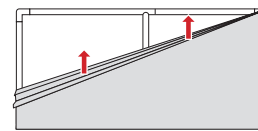
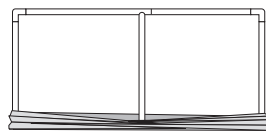

This document contains proprietary information. No portion may be disclosed to other, reproduced or used in any way without our written authorization.



©2018 McRae Imaging Inc.

SIZE SPECIFICATIONS:

THIS INSTRUCTION SHEET IS APPLICABLE FOR TRIANGLE HANGING SIGN.



FRAME ASSEMBLY

STEP 1: BOTTOM TRIANGLE

PARTS REQUIRED:  (No Hanging Points) x3
 x3
 x3



- ▶ Follow the number sequence
- ▶ Start building the bottom section by connecting parts together

STEP 2:

PARTS REQUIRED:  x3
 x3





- ▶ Connect the uprights to bottom section

STEP 3: UPPER TRIANGLE AND FRAME

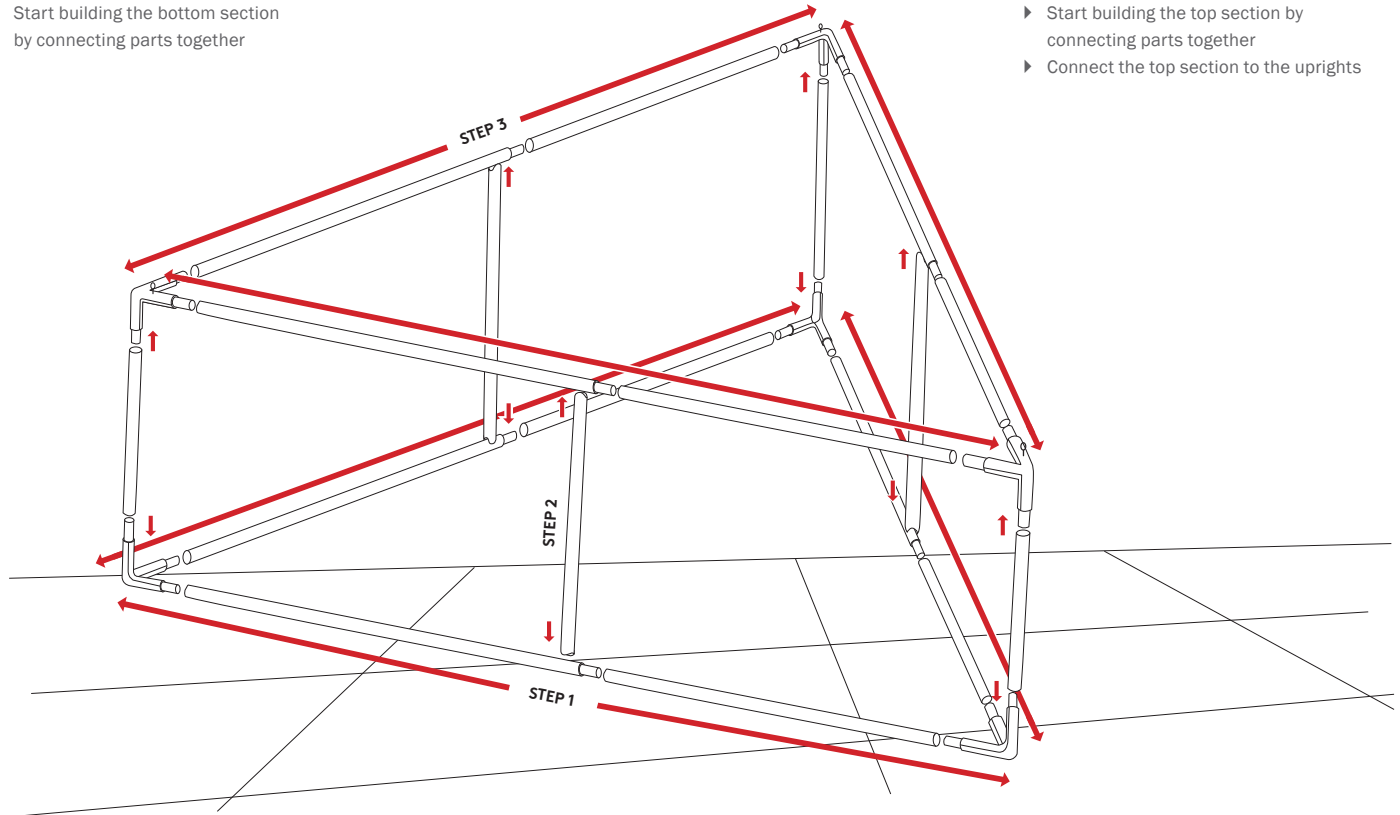
PARTS REQUIRED:  (With Hanging Points) x3
 x3
 x3

- ▶ Follow the number sequence
- ▶ Start building the top section by connecting parts together
- ▶ Connect the top section to the uprights



PARTS	QTY
 3 PCS. WITH HANGING POINTS	6
	6
	6
UPRIGHTS	
	3
	3

FABRIC INSTALLATION

- ▶ Make sure work area is clean of dirt and other materials that might damage or dirty the fabric. Use a drop cloth if possible & never use newsprint
- ▶ Put unzip fabric on the floor and open up the fabric.
- ▶ Put frame on top of fabric, make sure to match the button holes to the hanging points
- ▶ Pull the outside and inside fabric up and close zippers

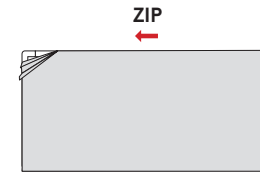
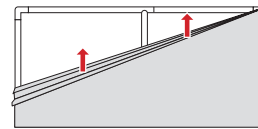
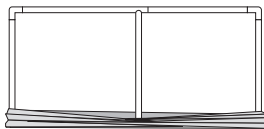





This document contains proprietary information. No portion may be disclosed to other, reproduced or used in any way without our written authorization.

©2018 McRae Imaging Inc.

SIZE SPECIFICATIONS:

THIS INSTRUCTION SHEET IS APPLICABLE FOR ALL PINWHEEL SIZES.

PARTS	QTY
	6
	6
	6
	3
STRAIGHT UPRIGHT	3
	3
CURVED UPRIGHT	3

FRAME ASSEMBLY

STEP 1: ASSEMBLE FRAMES A, B & C

- ▶ Follow the number sequence
- ▶ Start building **Frame A** by connecting Joints 1 - 10
- ▶ Start building **Frame B** by connecting Joints 11 - 20
- ▶ Start building **Frame C** by connecting Joints 21 - 30

STEP 2: INSTALL FABRIC

SEE INSTRUCTIONS BELOW

STEP 3: ASSEMBLE PINWHEEL

- ▶ Connect Joints 31 & 32
- ▶ Connect Joints 33 & 34
- ▶ Connect Joints 35 & 36

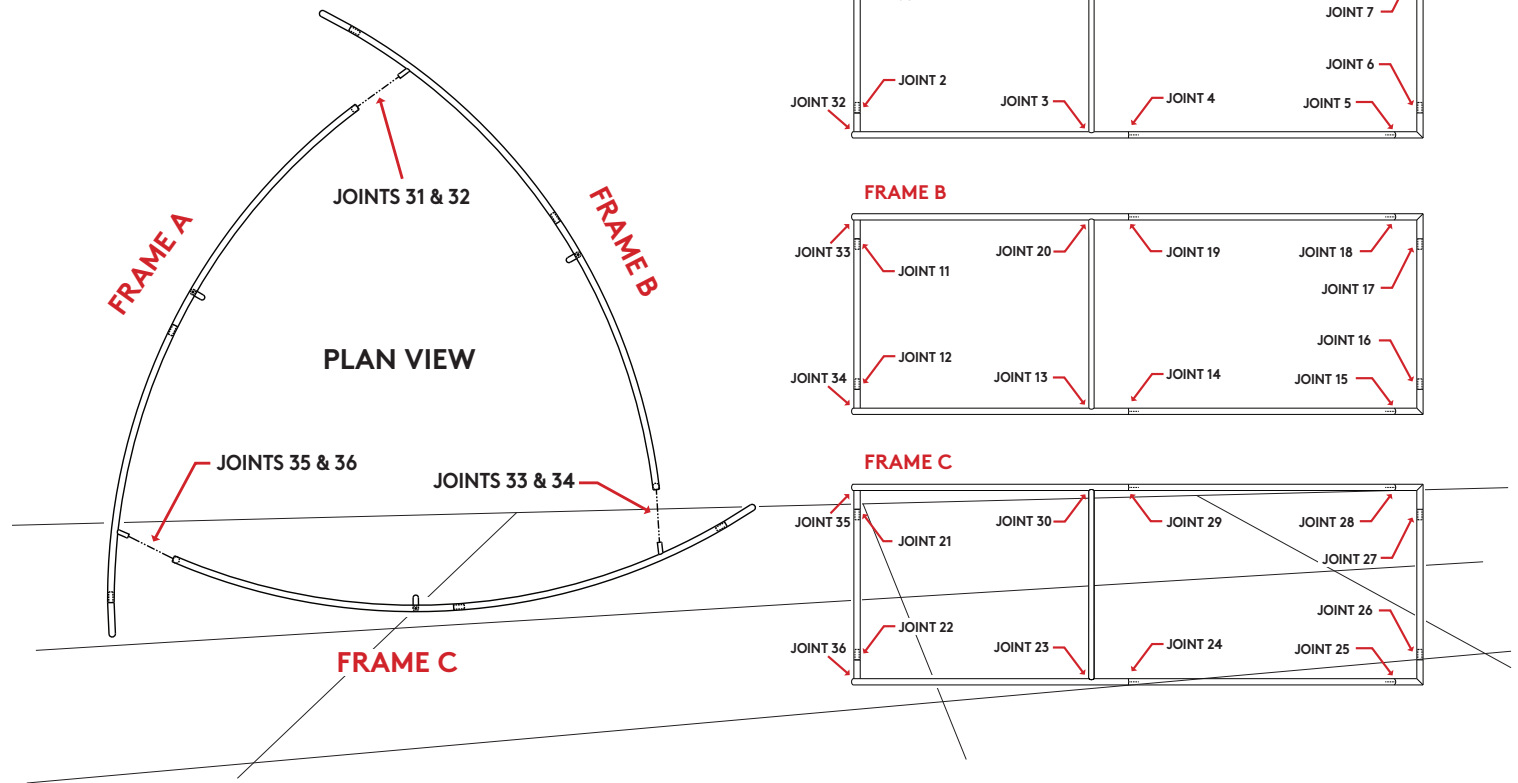

FABRIC INSTALLATION

- ▶ Make sure work area is clean of dirt and other materials that might damage or dirty the fabric. Use a drop cloth if possible & never use newsprint
- ▶ Put unzipped fabric on the floor and open up the fabric.
- ▶ Pull the fabric from one side of the frame to the other, like a sock. Make sure to match the button holes to the hanging points and fabric openings to the connecting joints and close zippers.

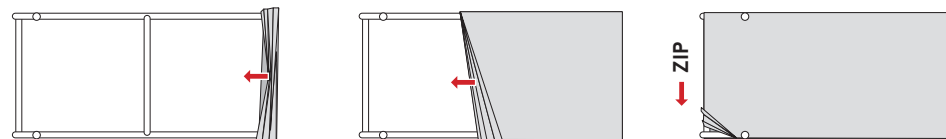

This document contains proprietary information. No portion may be disclosed to other, reproduced or used in any way without our written authorization.

©2018 McRae Imaging Inc.

THIS INSTRUCTION SHEET IS APPLICABLE FOR RECTANGULAR MILAN COUNTERS.



FRONT VIEW



TOP VIEW



ISOMETRIC VIEW

PARTS	CODE	QTY
	P1	4
	S1	4
	N1	1
	N2	2
	COUNTER TOP	1

FRAME ASSEMBLY

STEP 1: LOWER SECTION

PARTS REQUIRED: 4-S1, 2-N2

- ▶ Connect N2 to S1 for each side.
- ▶ Do the same way for the other side of the frame

STEP 2:

PARTS REQUIRED: 1-N1

- ▶ Take Lower Section from STEP 1
- ▶ Connect N1 to N2 for each side

STEP 3:

PARTS REQUIRED: 4-P1

- ▶ Take Lower Section from STEP 2
- ▶ Connect P1 to S1

STEP 4: INSTALL FABRIC

SEE INSTRUCTIONS BELOW

STEP 5:

PARTS REQUIRED: COUNTER TOP

- ▶ Place Counter Top in place and screw it with P1 on 4 corners from the bottom

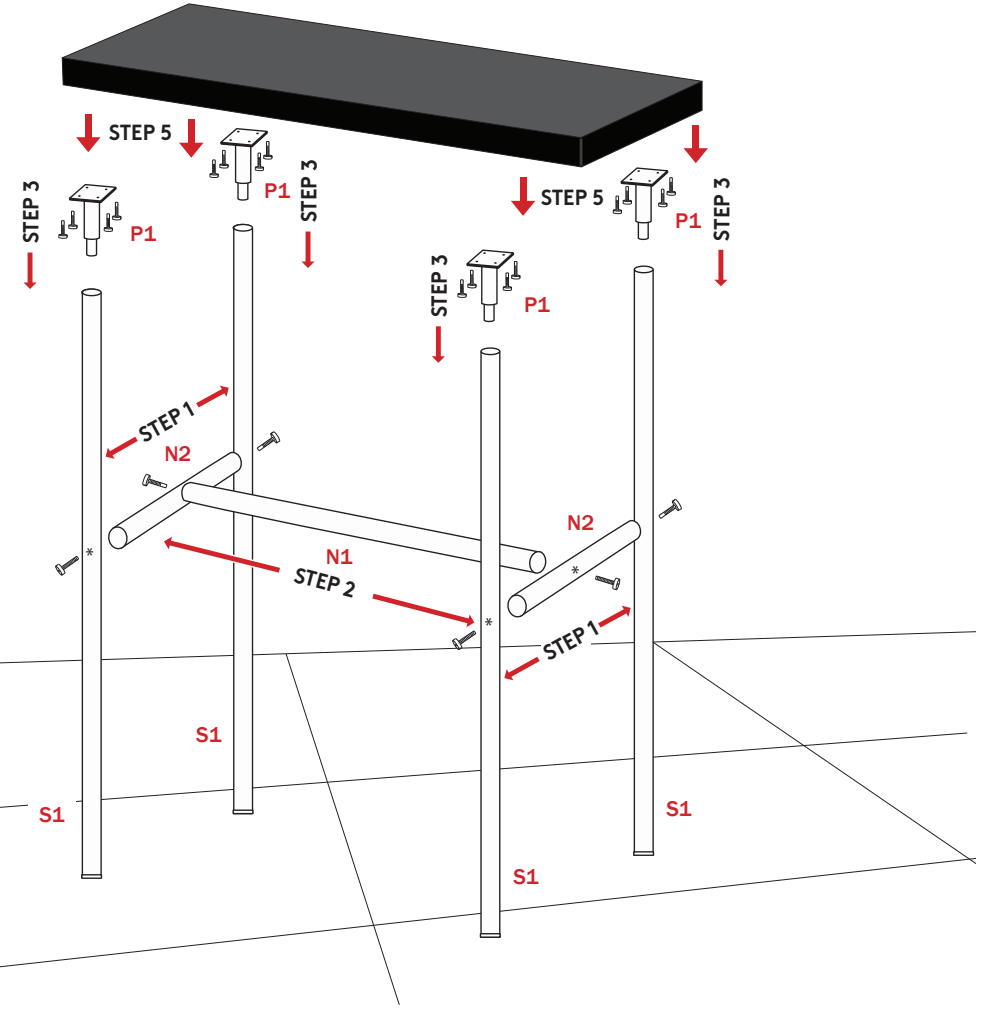

FABRIC INSTALLATION

- ▶ Make sure that floor is clean. If possible use a drop cloth.
- ▶ Locate the opening on the fabric
- ▶ Make sure that zippers are open
- ▶ Drape fabric like a pillow cover to the frame starting at the top
- ▶ Pull the fabric all the way down and close zippers

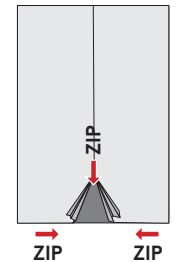
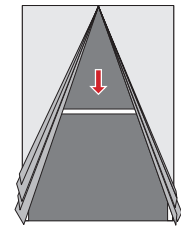
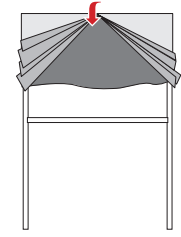

This document contains proprietary information. No portion may be disclosed to other, reproduced or used in any way without our written authorization.

©2018 McRae Imaging Inc.

THIS INSTRUCTION SHEET IS APPLICABLE FOR D-SHAPED MILAN COUNTER.



FRONT VIEW



TOP VIEW



ISOMETRIC VIEW

FRAME ASSEMBLY

STEP 1:
PARTS REQUIRED: TOP & BOTTOM SECTIONS, 3-UPRIGHTS, INSIDE SHELF





- ▶ Follow the number sequence
- ▶ Connect Uprights to Bottom Section
- ▶ Connect Top Section
- ▶ Place Inside Shelf by lining up notches to the bottom of frame

STEP 2: INSTALL FABRIC
SEE INSTRUCTIONS BELOW

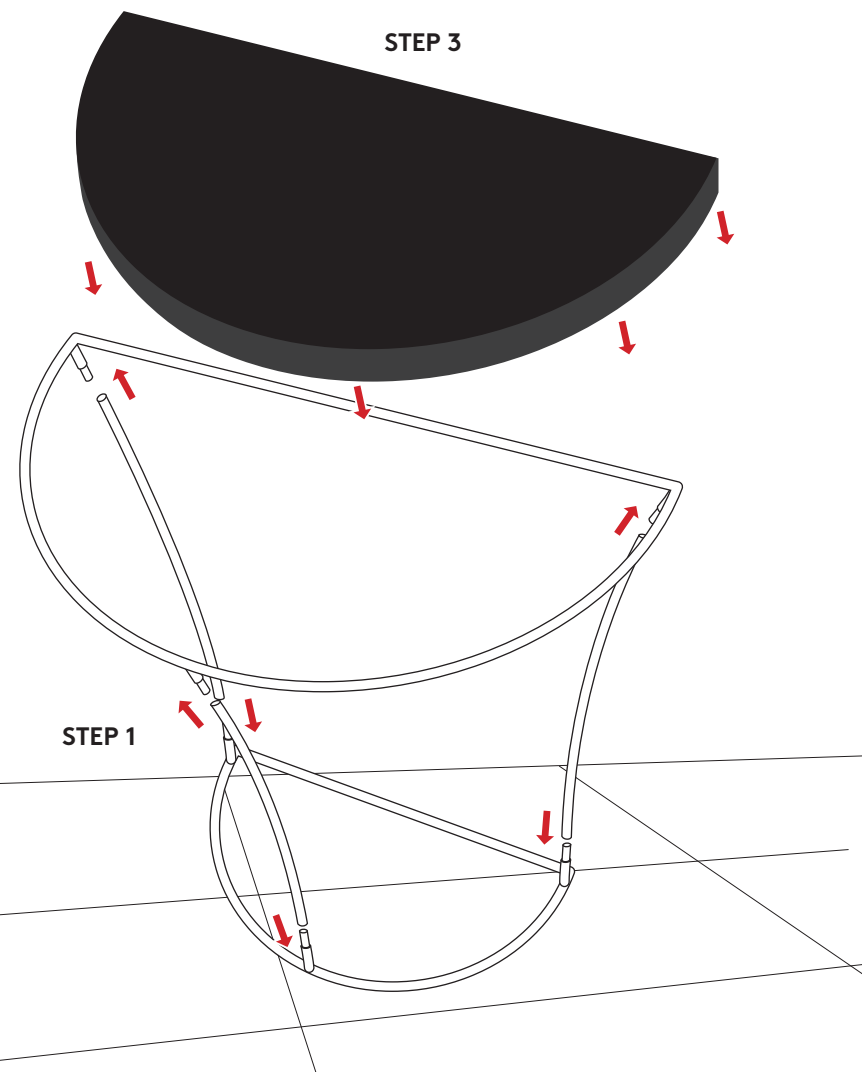
STEP 3:
PARTS REQUIRED: COUNTER TOP

- ▶ Place Counter Top on top of frame



PARTS	QTY
TOP & BOTTOM SECTIONS	
	2
UPRIGHTS	
	3
COUNTER TOP	
	1
INSIDE SHELF	
	1



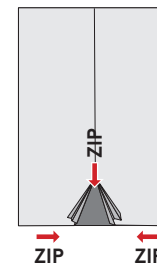
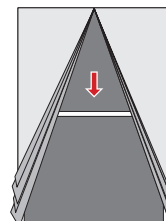
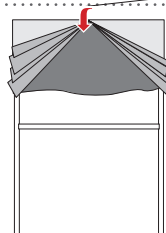

FABRIC INSTALLATION

- ▶ Make sure that floor is clean. If possible use a drop cloth.
- ▶ Locate the opening on the fabric
- ▶ Make sure that zippers are open
- ▶ Drape fabric like a pillow cover to the frame starting at the top
- ▶ Pull the fabric all the way down and close zippers

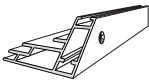

This document contains proprietary information. No portion may be disclosed to other, reproduced or used in any way without our written authorization.

©2018 McRae Imaging Inc.

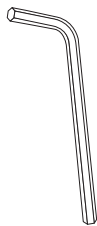
PARTS	QTY
	EXTRUSION FRAME 4
	CORNER CONNECTORS 4
	LED LIGHTS
	LED DRIVER
	SCREWS 8
	ALLEN KEY 1

FRAME ASSEMBLY

STEP 1:

- Lay out the extrusion on the ground in a box shape.

STEP 2:

- (FIG 1A) Slide the corner connectors into the top and bottom profile.

STEP 3:

- (FIG 1B) Slide the side pieces into the top and bottom. Secure the corner bracket with an allen key.

STEP 4:

- (FIG 1C) All lights and wires are pre-mounted to the frame. The wire connectors will click into each other creating a chain pattern.

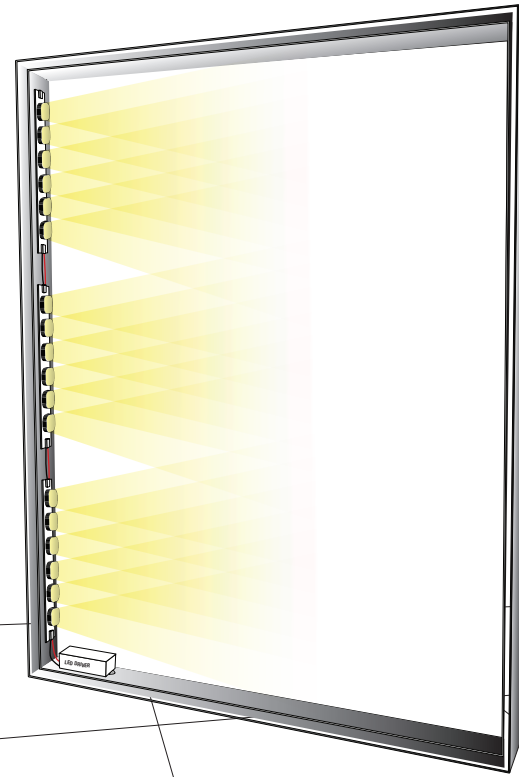
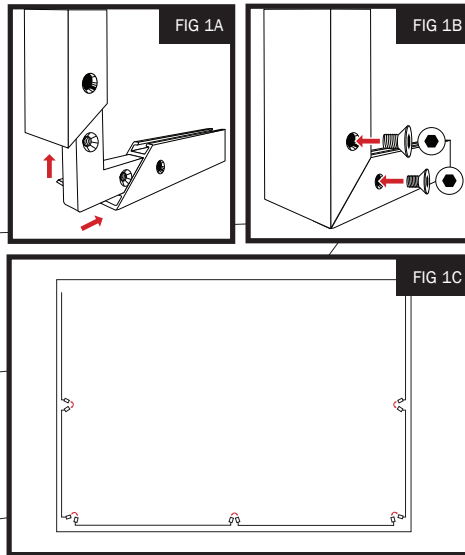

NOTE:
THIS SIGN IS INTENDED TO HAVE GRAPHIC DISPLAY APPLIED TO THE FACE OF THE FRAME.
THIS SIGN MUST BE PLUGGED IN TO GROUNDED ELECTRICAL OUTLET.

WALL MOUNTING

- Mark the wall and screw using the pre-drilled holes on the frame.

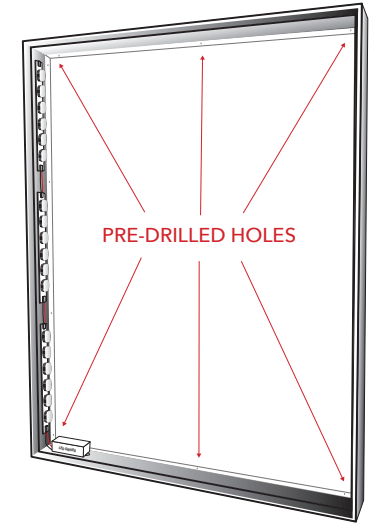

NOTE: MOUNTING HARDWARE NOT PROVIDED

FABRIC INSTALLATION

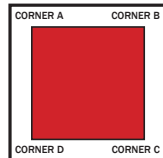

It is important to first insert graphic into each alternate corner then to the sides of the frame. If this is not done, graphic will not fit into the frame properly.

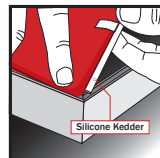

STEP 1: Insert CORNER A. Turn edge of graphic so silicone kedder is perpendicular to face of graphic. Insert narrow side of welt with fabric to outside into the channel. Repeat for other side of this corner.



STEP 2: Repeat STEP 1 for CORNERS B, C & D to complete installation of the corners.



STEP 3: Once all corners are inserted, press one silicone edge to channel from the center and working toward the corners. Make sure kedder is fully inserted into the channel. Continue until all sides are done. Smooth out edges of graphic.



GRAPHIC REMOVAL: To remove graphic from the frame, locate the pull tab and gently pull up on the tab.



This document contains proprietary information. No portion may be disclosed to other, reproduced or used in any way without our written authorization.

©2018 McRae Imaging Inc.