





## SIZE SPECIFICATIONS:

THIS INSTRUCTION SHEET IS APPLICABLE FOR ALL PINWHEEL SIZES.

PARTS	QTY
	6
	6
	6
	3
STRAIGHT UPRIGHT	3
	3
CURVED UPRIGHT	3

## FRAME ASSEMBLY

### STEP 1: ASSEMBLE FRAMES A, B & C

- ▶ Follow the number sequence
- ▶ Start building **Frame A** by connecting Joints 1 - 10
- ▶ Start building **Frame B** by connecting Joints 11 - 20
- ▶ Start building **Frame C** by connecting Joints 21 - 30

### STEP 2: INSTALL FABRIC

SEE INSTRUCTIONS BELOW

### STEP 3: ASSEMBLE PINWHEEL

- ▶ Connect Joints 31 & 32
- ▶ Connect Joints 33 & 34
- ▶ Connect Joints 35 & 36

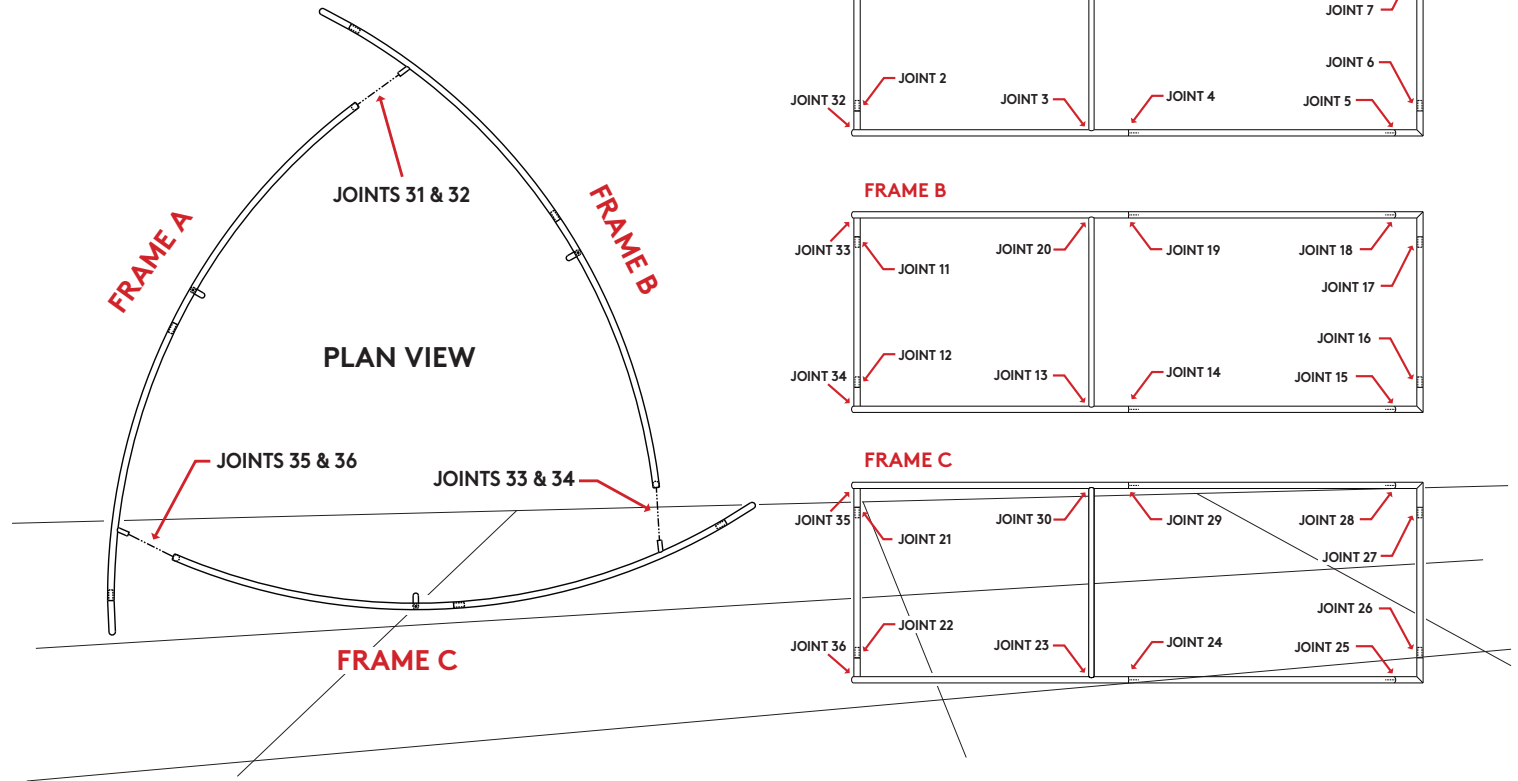

## FABRIC INSTALLATION

- ▶ Make sure work area is clean of dirt and other materials that might damage or dirty the fabric. Use a drop cloth if possible & never use newsprint
- ▶ Put unzipped fabric on the floor and open up the fabric.
- ▶ Pull the fabric from one side of the frame to the other, like a sock. Make sure to match the button holes to the hanging points and fabric openings to the connecting joints and close zippers.

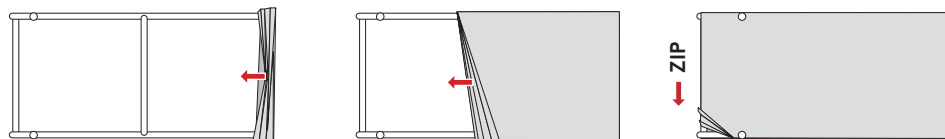

This document contains proprietary information. No portion may be disclosed to other, reproduced or used in any way without our written authorization.

©2018 McRae Imaging Inc.